



FINAL REPORT



TERRY AUSTEN (ME)
ANDREW HUISJEN (ME)
KEVIN PALMER (ME)

ENGR 340
MAY 13, 2005

TABLE OF CONTENTS

1. INTRODUCTION AND BACKGROUND	2
-PROJECT MOTIVATION	2
-ECONOMIC CONSIDERATIONS	3
-ENVIRONMENTAL DISCUSSION	4
2. PROJECT OBJECTIVES	5
-PROJECT SCOPE	5
-DESIGN NORMS	6
3. DESIGN ALTERNATIVES	7
-DESIGN CONCEPT DECISION	7
-DESIGN EVOLUTION	13
4. FINAL PROTOTYPE DESIGN	16
-OVERVIEW	16
-BASE	17
-A-FRAME	18
-BACK LEGS	19
-SWIVEL CONNECTION	20
-BOOM	23
-WINCH AND GRABBERS	25
-OUTRIGGERS	25
-TRAILER	26
5. TESTING AND DESIGN CHANGES	26
-OVERVIEW	26
-TESTING INDUCED PROTOTYPE CHANGES	27
-THEORETICAL FUTURE DESIGN CHANGES	29
6. BUDGET	31
7. SCHEDULE	33
8. CONCLUSION	36
9. APPENDICES	37

1. INTRODUCTION AND BACKGROUND

PROJECT MOTIVATION

Calvin College teaches engineering from a Christian perspective; therefore, the engineering department focuses on the many ethical issues that we, as engineers in industry, will be faced with on a day-to-day basis in the near future. Calvin also focuses on ways that we as engineers can use our gifts and skills of engineering to live a service-oriented life and be of help to others. As a result, there has been a slight trend toward service project-oriented senior design projects over the last few years. Though this service aspect of the project is certainly not a requirement of the course, nor a required aspect of many other engineering projects, it is an exciting option for many students to pursue.

At the time that our group was formed shortly after the fall semester began, we really had no good ideas for a project. We had a number of unrealistic brainstorming ideas, but the entire group was unable to agree on what should actually be done. Then we received an email from Professor VanderLeest about a project that had been proposed by a Calvin graduate, James Kuiper. Kuiper works as a teacher on the Zuni Native American Reservation near Taos, New Mexico, and is interested in constructing a home out of old tires. However, this type of house is very time-consuming to build because each tire must be packed with dirt by hand, which can take a very long time. He proposed that a senior design team from Calvin design and build a tire-packing machine that would make the building process for this type of house quicker and less labor intensive. Terry Austen took a specific interest in this project, and convinced the rest of the group that it was a worthwhile project to pursue. With Terry acting as this driving force, our group decided that this was indeed what we wanted to do.

Shortly after we came to this decision, we heard rumors that another senior design group had also decided that they wanted to pursue it. This conflict led to a number of meetings between our group and the other group, and together we also contacted James Kuiper to see if he had any other potential senior design project ideas that could be spun off of the tire packer idea. By the end of the week, a second idea had come up that involved building a lift to place the packed tires on the wall as the house was built. Our group decided that we would take on this project.

The type of house that Kuiper is aspiring to build is called an “Earthship”, named by its inventor, Michael Reynolds. The concept of these “Earthships” is to use old truck tires to build a fully self-sustaining house. Earth is firmly packed into the whole tire to form a 300 lb tire brick. These are then stacked just like bricks to form the walls of the house. These houses are particularly effective in desert areas with cool evenings and very hot days. The earth in the tires basically acts as a big “thermo-economizer” for the house. During the day, the earth and tires will soak up much heat from the sun, keeping it from the inside of the house; when night comes, they release the heat to the inside, therefore keeping it at a constant and comfortable temperature.

Kuiper wishes to build and live in an Earthship in order to show the Zuni natives that Earthships are a cost-effective way to inexpensively build, heat, and cool a home. Currently, the Zuni tend to rely on either wood or natural gas to heat their homes at night. Since it is a desert region, the wood supply is running thin, and natural gas prices have been rising (as they have throughout the nation). For these reasons, Earthships should be very appealing for this part of the country; unfortunately, the large time commitment and difficult labor involved with building these houses turn many people away from them. Current construction methods involve manually packing the tires with sledge hammers; this can take a person up to 45 minutes when not tired, and potentially much longer as they become fatigued over the course of the work day. Under these conditions, a typical 1200-tire house can take up to 3 years to build even with a substantial amount of help. This is not appealing to the Zuni natives. The tire packer being built by Team #4, “Solar Thermal Packing”, coupled with our lifter, could effectively reduce the 1-tire cycle time to as low as 10-15 minutes, and this could allow for the walls of an Earthship to be built in as little time as 3-4 weeks (optimistically). Kuiper hopes to show that one of these cost-effective and thermally efficient houses can be built in a feasible amount of time.

ECONOMIC CONSIDERATIONS

Since our project has to lift large loads over many cycles, it must be very structurally sound. We had to choose our materials to be high in strength but low in cost. Also, due to budget constraints we decided to make all movements, besides vertical, controlled manually. This saved both a lot of money that could have been spent on extra components and design time that would have been spent integrating these components.

ENVIRONMENTAL DISCUSSION

When we first proposed our project to our professors, they raised an important question: Are tires safe when they are decomposing, or do they let off harmful gases? It was important for us to have an answer to this question because we did not want to aid in building homes that would be harmful to their occupants. As we researched tire decomposition, we came into contact with James Lee of the EPA, who led us to a few websites to look at. One of the sites said that the “EPA does not consider scrap tires a hazardous waste.”¹ This was good news to us since it was from an unbiased source that had no vested interest in our project. We had also read some other pieces about this issue from people who had actually built and/or lived in Earthships, but we had to consider these sources to be somewhat biased simply because of their connections to Earthships.

Even though we felt comfortable about the safety of the decomposing tires, we still wondered why tires would cause problems in landfills but not in houses. This question has a fairly simple answer: the tire’s shape. Since a tire has a lip inside of it, gases can be trapped inside the tire. The decomposing garbage in landfills creates a substantial amount of methane that comes up out of the ground. When a tire is put in a landfill, this methane gas gets trapped inside the tire. Methane has a lower density than air and thus causes the tire to “float” to the top of the landfill and ruin the design of the landfill. This gives people a general misconception that old tires themselves are actually dangerous. This concern is misguided, because the methane gas is not produced by the tire. Since the houses we will be helping to build are not built on landfills or with other decomposing garbage items that would give off methane or other gases, we need not worry about this problem. The only problem that exists with using tires for houses is the fire hazard. Burning tires are very dangerous. However, the tires will be firmly surrounded with packed earth that will strongly inhibit their ability to burn, and burning is also a hazard associated with conventional wood homes. We do not consider fire hazard an issue worth scrapping the entire project over.

¹ <http://www.epa.gov/epaoswer/non-hw/muncpl/tires/fires.htm>

2. PROJECT OBJECTIVES

WHAT DO WE NEED OUR MACHINE TO DO?

PROJECT SCOPE

Our original basic objectives for this project were summed up in our early project scope:

ORIGINAL SCOPE: We will design and build an electrically powered machine that must lift and place 300 lb truck tires packed with earth onto the walls of an “Earthship”, which will be built up to 9 ft in height during construction.

This statement gave the overall idea of what we were trying to accomplish, and initially we broke this idea down into many more specific objectives, some of them simple, and some of them rather complicated. These ideas included lifting multiple tires at once, implementing electronic control for all types of motion so the machine could be operated from one location, and making the machine a self contained mobile unit. However, as we dug deeper into our project and moved toward a final design, we were able to understand better what exactly it was that we needed to accomplish for this project to be a success. Through this process, we were able to better refine our scope to more specifically describe the focus of our project:

NEW SCOPE: We will design and build a working prototype of a crane to aid in the construction of “Earthship” tire houses. The crane must rotate 360°, be able to withstand a load of 500-lb at a radius of 10-ft, and be able to lift a packed tire to a height such that the bottom of the tire clears 8-ft. The crane must also be mobile, collapsible, and have the ability to disconnect into components.

This statement can be broken down into its major points to get a better idea of our specific objectives:

-Working prototype crane: Our final machine that we produce will be a prototype crane that demonstrates the function of the design, but isn’t necessarily intended to be used to actually build an Earthship; rather our prototype is another step in the design process that helps work toward a better final design.

-360° Rotation. The boom of our crane will rotate in a complete circle to give it good flexibility and ease of use on the construction site.

-500 lb load. A packed tire weighs between 300 and 400 lbs, so we want our crane to be designed with a slightly higher load in mind (500 lb was a good base load used for all calculations before any safety factors were designed in, so our design will not fail when subjected to greater loads).

-Need to place the tire on an 8 foot high wall. Our crane must have a device that can grip the tire effectively so that it can be placed easily on top a wall. The maximum height the walls will be built to is 8 feet.

-Mobility. Our crane will be mounted to a trailer, allowing it to be towed around the construction site easily by a pickup truck or similar vehicle.

-Collapsibility. Our crane must fold down so that it is not permanently sticking up 10 feet or so in the air. Making the crane collapsible also enables greater mobility (it can easily be driven around on roads, can fit through a fast food drive-through, etc.)

-Components. The crane must come apart piece by piece so that it can easily be taken down and stored when not in use. A whole crane that is one piece would be far too heavy and awkward to move around and store, but components can each be carried by 1 or 2 people with relative ease.

DESIGN NORMS

Any design project at Calvin College will have an emphasis on implementing several design norms into the project, and this project is certainly not exempt from this. Arguably, the most evident norm in our project is **stewardship**. We are putting some of the millions of waste tires to a practical and non-detrimental use. Also, by helping to construct these houses, we will hopefully be decreasing the depletion of natural resources such as wood and natural gas while at the same time lowering the cost of living for the Zuni natives. Another design norm evident in our project is **caring**. By accomplishing our goals we will be caring for the Zuni natives by helping to reduce their cost of living with no tangible benefits to ourselves (well, other than hopefully receiving credit for ENGR 339 and 340 and getting our college degrees). Also, by producing this product we will be providing a way to aid the construction of their houses at hopefully no cost to them. Another design norm evident in our project is that of **integrity**. In order to model integrity, we feel that we need to produce a quality product, not just to show that we are capable and ready to produce quality products now and in the future, but also to show that we have an active interest in how our product will benefit the users practically and aesthetically. Modeling integrity also means that we will conduct ourselves in a

professional manner in all aspects of the project, especially in the area of communication and acknowledgements. Finally, the last design norm evident in our project is **transparency**. Our machine will be easy to use and set up, and will require very little training to use effectively. We are building a machine in a significantly different cultural setting from that in which it will be used, so consideration of how it will blend into that situation is also very important.

3. DESIGN ALTERNATIVES

HOW DO WE DECIDE ON A DESIGN?

DESIGN CONCEPT DECISION

After determining the basic specifications that we needed our machine to meet (see our original scope above), we brainstormed different combinations of features that could potentially satisfy these needs. This process was also a major factor in helping us to refine our scope. The major design concept decisions that were left were the following:

- Will the machine lift 1 or 2 tires?
- Will the machine swivel or be fixed?
- Will the machine be a crane design or a vertical lift design? (“crane” meaning a long boom sticking out from the top; “vertical lift” meaning a whole platform that moves up and down)

These three decisions create eight different design concept possibilities; a decision matrix was used to help determine the best of these eight concepts (Table 3.1):

Table 3.1: Design Idea Decision Matrix

	<i>Usefulness</i>	<i>Cost</i>	<i>Safety/stability</i>	<i>Durability</i>	<i>Mobility</i>	<i>Size</i>	<i>Ease of Build</i>	<i>Sex Appeal</i>	<i>Shalom</i>	Total
<i>Weight:</i>	28	17	16	11	10	8	7	1	2	100
Swivel 2 tire crane	20	9	9	7	5	5	2	1	1	59
Swivel 2 tire track	17	8	11	6	5	5	2	1	0	55
Fixed 2 tire crane	11	15	12	10	7	7	5	1	0	68
Fixed 2 tire track	3	15	13	9	7	7	5	1	0	60
Swivel 1 tire crane	24	13	13	9	9	7	4	1	2	82
Swivel 1 tire track	7	12	14	7	9	7	4	1	0	61
Fixed 1 tire crane	8	17	14	11	10	8	6	1	0	75
Fixed 1 tire track	3	17	15	10	10	8	7	1	0	71

The following section describes how each category was judged:

USEFULNESS

The most important aspect of our machine is its usefulness. If our design cannot successfully place tires on the wall in a time-saving manor, our team has not achieved its goal. For this reason, usefulness was made the heaviest weighted aspect of our decision matrix.

Initially we thought that the more tires we could lift at once, the more useful the lift would be, because it would be able to do the necessary work faster. However, after our experience of packing a tire and experiencing firsthand how heavy and awkward they can be, we determined that the machine's ability to place a tire exactly where it is needed was more important than its ability to lift multiple tires quickly. With the multiple-tire lift designs, the precision placement of a tire would be much more difficult to achieve. Our ideas for placing multiple tires involved either tipping the tires out of a tray and onto the wall or rolling the tires out of a track onto the wall. Neither of these designs could really work to place the tire with precision. Rolling the tires out of a track would be very difficult and potentially dangerous; a packed tire is very difficult to roll on flat ground, let alone in a track that's 8-feet in the air or on top of a wall of tires.

The two ideas for the actual structural system were a crane style boom arm with a free hanging cable on the end or a forklift style platform that operates on a fixed track. Since the placement of the tire is so important to the usefulness, the crane was determined to be the better of these alternatives because it would have greater adjustability. The forklift style would require the entire machine to be placed exactly in the right spot along the wall in order to place the tire well, requiring that the machine be repositioned along the wall before each tire could be placed. The crane would be able to sit in one spot and reach a longer section of the wall.

The final decision was whether or not the machine should be able to swivel. A swivel mechanism would the machine more useful, because it would allow it to pick up the tires behind the machine and then swivel around to place them on the wall in front of the machine. With this idea, the tire packer could be placed behind the machine, and the machine could grab a tire immediately after it is packed and place it on the wall without needing to move the machine or a packed tire over a long distance. Furthermore, the

swivel would allow for much more adjustability in placing the tire, especially when combined with the lateral motion of the winch.

The method of placing a tire must be precise enough to build a sturdy wall. Currently, the tires are stacked up by hand when they are empty, and then packed with sledge hammers while they are on the wall. The workers simply must eyeball where the tire is to go based on where the existing tires already are, and then the workers pack them. Pounding the tires with sledge hammers as they are packed likely moves them slightly away from their original position. The point of all this is that there is no set tolerance that says exactly where the tires must be placed. The wall becomes stable enough through just eyeballing the tire placement and then securing it with rebar. A machine that has multiple ranges of motion (vertical, lateral, swivel) would make it easy to place the tire in exactly the right spot on the wall; with the crane design, lifting the tire from a free hanging cable would allow for hand guided adjustments as the tire is lowered onto the wall, giving the crane concept a level of precision not as easy to achieve with the forklift design concept. The eyeballing technique will still be used as it was before, but the tire being placed would already be packed, and it would be placed by machine rather than by hand.

COST

Cost was determined to be the next most important aspect of our design. Our budget was small, at around \$500, and we needed to design something that we could actually afford to build with this amount. The bigger and more ambitious the design, the greater the cost of materials would be. However, after talking to Dave Ryskamp about availability of steel, we had some hope of obtaining a considerable amount of the necessary steel at little or no cost. For this reason, we determined that the cost considerations would change less with the size of the design than we originally thought.

Designing a swivel mechanism into the machine would require some sort of bearing and/or shaft system to allow for easy rotation. This was determined to be a potentially costly addition to the project.

To lift two tires rather than one, a larger winch would be necessary, most likely costing more than a smaller winch. The structure would also need to be stronger, and this could raise costs if more steel were necessary.

Another cost consideration that should have been included in this decision was the cost to reproduce the crane beyond just the prototype that we were to build for this project. However, at the time these decisions were being made, we were hoping that the prototype would also be the crane that could be used by Jim Kuiper in New Mexico, making it unnecessary to build a second one.

SAFETY/STABILITY

Safety is a very important aspect of this project. Our machine must not put anyone in danger. For the machine to be safe, it must pick up tires with no danger of dropping them, it must place tires gently with no danger of them sliding off the wall, and the machine must be stable and avoid tipping over or breaking. Placing just one tire instead of two was determined to be a safer design—there would only ever be one tire in the air, so the operators could focus all of their attention on that one tire without having to watch a second tire in the air that could cause a potential hazard. Placing one tire would simplify the process and minimize the potential for a mistake such as accidentally releasing the wrong tire or knocking something over with the extra hanging tire. Furthermore, lifting just one tire would make for a much lighter load, and thus would make the machine more stable when the tire is raised up in the air.

DURABILITY

Our machine needs to be able to withstand the potentially harsh conditions of the worksite at which it will be used. The weather in New Mexico can range from very hot and sunny to very cold at night, and our machine must handle both of these issues (not because it will be operating at night, but simply because it will be sitting at the construction site overnight). More importantly, it must be able to perform its task of placing tires over and over again without problems.

Any moving parts would need to be designed and built in a way so that would not wear quickly and would continue to operate well through frequent use. Generally, a fixed crane would be more durable than the other designs because of its simplicity—there are no moving parts save for the motor/pulley/cable system that actually lifts the tire.

Introducing a forklift-style track into the lifting process could bring with it some wear issues because of the sliding friction present in the track; using a crane design with a boom could bring some issues of bending because of the large moment caused by the length of the boom.

A durability issue could arise in a swiveling mechanism. Whatever the type of swivel mechanism used, whether a shaft in a sleeve or some sort of bearing, it would need to be strong enough to hold large loads and large moments. Since the tire would be hanging off center from the swivel point, there would be uneven loading on this mechanism. For this reason, the design options that included swivel mechanisms were given lower durability ratings, and the heavier the load on the swivel mechanism, the lower yet the given durability rating.

MOBILITY

Our machine must be mobile enough to easily get around the construction site so it can be repositioned to build different rooms. While good mobility is important to the overall success of the project, it was not given a particularly high weighting on this decision matrix because we figured that the mobility was not drastically dependent on what design we chose. The machine will be mounted on some sort of rolling base or trailer that can be towed around by a truck on the site regardless of the design of the rest of machine.

With this said, the larger the machine is, the less mobile it will become. If the machine must lift two tires, it would be larger than a one-tire machine, and thus would weigh more and be harder to move around. Designs with a swivel mechanism were determined to be potentially less mobile because of the possibility of machine swiveling as it is moved over uneven ground or around turns.

SIZE

Our machine will be large. For a crane design, the boom would need to tower about 9- or 10-feet in the air in to lift the tire high enough to place it on the wall. The boom would also need to extend 9 or 10 feet out from the center of the machine. This means that the base would also have to be fairly wide in order to give the machine sufficient balance. A forklift style machine would also need to be tall, though it would not need to have a 10-

foot reach; however, it would still need a large base to maintain stability, especially since it would require frequent repositioning along the wall.

Our goal was to be able to build the smallest machine possible that would effectively perform the task of lifting and placing tires. The larger the machine, the more difficult it would be to move and build, and increase the cost potential. Basically, the more complicated the design, and the more tires we want it to lift, the larger the machine would be. In the cases of the swiveling forklift designs, the machine would be particularly large. This is because the forklift track, which we envisioned extending down toward the ground, would need to be able to clear the corners of the base in order to swivel and be useful. This would make the actual swiveling portion of the machine much larger than if the swiveling portion were just the boom of a crane.

EASE OF BUILD

Ease of build of our machine was not a top priority, but was nonetheless important to the success of the project. As inexperienced engineering students who were really getting our first big taste of an entire design and build process, we didn't need to be taking on more than what we could realistically handle. We were somewhat limited by the tools and construction technology available to us, and also limited by our own developing abilities in fabrication. With that said, ease of build was not a huge concern, because we felt that as long as we could stay on course with our schedule, we would have plenty of time to construct our machine and overcome any obstacles that came up along away.

The simplest design, the one-tire fixed crane, looked to be the easiest design to build. It required the fewest parts, and had the lowest level of needed fabrication precision. Adding a vertical track to this basic design would have made it only minimally more difficult to build, as would designing in the capacity to lift two tires (the only thing that it does is make the machine bigger, but not more complicated). The swivel mechanism looked to be the most difficult aspect of fabrication.

AESTHETICS

Part of designing in engineering is to make a product that not only serves its purpose, but also looks nice. There is a certain pride that comes from designing a product, and part of that pride comes from successfully blending function with aesthetic.

Unfortunately, when creating an inexpensive tire lifting machine out of steel, there may not be a lot that can be done concerning the aesthetics of the machine. Each of our alternative designs would likely look nearly the same as the others upon completion. We figured that even though the machines wouldn't be objects of beauty from an artist's perspective, they would have the beauty of raw industrial function; therefore all design possibilities received a maximum rating of 1 for aesthetics.

SHALOM

A long-standing goal of the engineering department here at Calvin, and also of Calvin College as a whole, is to equip students to go out into the world and help restore shalom. If our machine is not able to help make a small contribution toward this restoration, we have failed as Christian engineers. To help restore shalom, our machine must truly make the lives of those building Earthships better than their lives before they had the tire lift. Some of our design concepts simply did not do this. If our lift had no swiveling device, it would not be easy to use—the tires would have to be rolled all the way to the tire wall, and the machine would need to be positioned perfectly in order to place the tire in the right place. This would make it very unfriendly to the people using it, and would not be restoring shalom. If our lift operated with a forklift style track, it would also be difficult to incorporate both lateral motion and swiveling motion to the machine. The combination of these two motions is vital to the machine's ability to place the tire with precision and speed, and also vital to being able to place more than one tire on the wall before the lift must be repositioned.

These issues ruled out all designs except for the swiveling crane concepts. These design concepts allow for the easiest and most precise placement of the tires. Lifting two tires at once introduces some extra safety concerns, and putting people's wellbeing in danger cuts down on the machine's ability to help restore shalom. For this reason, the 1-tire swivel crane gets the maximum shalom points, and the 2-tire swivel crane gets half of the possible shalom points.

DESIGN EVOLUTION

Through the decision matrix process, we decided that the best concept to follow for our machine design was the **1-tire swivel crane**. However, this concept alone did not give

us a final design. Our machine, from here on referred to as a crane, went through three major design phases before we arrived at our prototype design.

BOX FRAME DESIGN

Our first major structural design (Figure 3.1) was a large boxy vertical frame made of square tubing, and came to be called the “Pre-Chuck” design, referring our industrial consultant, Chuck Spoelhof—this was the design we were working on before our meeting with him. The idea with this design was to create a large vertical frame that

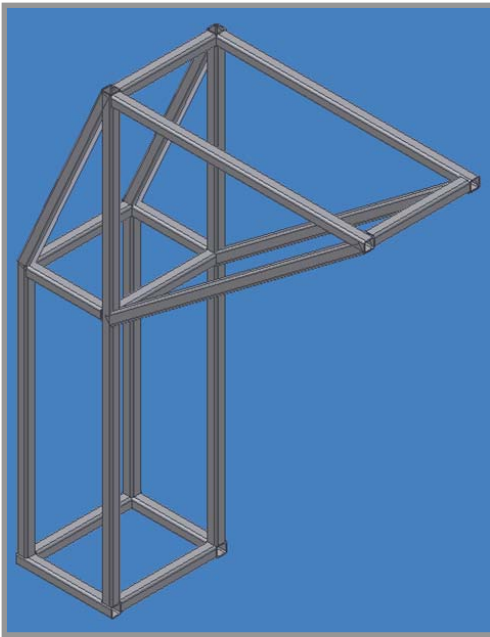

Figure 3.1: Box Frame Design

extended out to support a boom arm (not present in the picture). The entire frame was to be mounted to a turntable at the bottom, with the turntable being mounted to a trailer-like base that would be mobile on the ground.

This design was far more complicated and clunky than necessary. It used a lot more material than we desired, which made it weigh a lot. The turntable idea was determined to not be practical—why rotate basically the entire crane when rotating only the boom arm will accomplish the same result? This design also was based almost entirely on rectangular shapes in the structure, and this generally is a very inefficient

design in terms of strength vs. amount of material used. It also would have had no possible way to collapse down easily for storage purposes. Chuck Spoelhof helped steer us away from this design and helped us simplify to our next phase.

PYRAMID DESIGN

Our second major structural design (Figure 3.2) was a pyramid made of angle iron that supported a long vertical pipe that enclosed a rotating shaft on which the boom arm was to be mounted. This design came to be known as the “Post-Chuck” design, because it was inspired by some ideas given to us by Chuck Spoelhof during our consulting meeting with him. Spoelhof worked for Kodak for many years, so naturally he was very

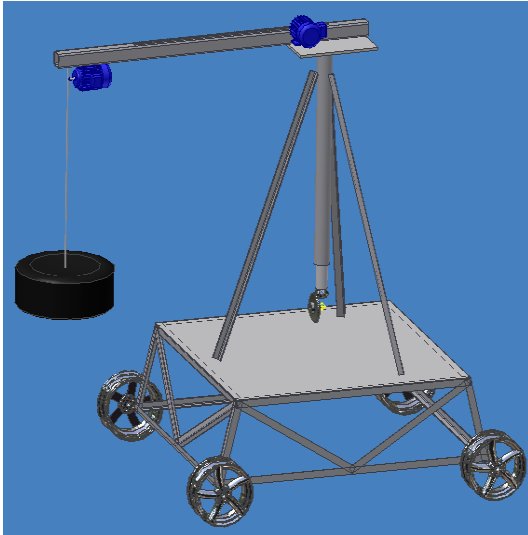

Figure 3.2: Pyramid Design

As this design developed more, there were still many unanswered questions about how the various mechanisms would work, how structurally sound we could make it with angle iron, and how we would be able to build the base and make it usefully mobile. It was also still not easily collapsible, which would again make it hard to transport down to New Mexico or store somewhere when not in use. While this design was a step in the right direction, it was still just that—a step. Many more needed to be taken before the design became satisfactory.

TRAILER FOLDING DESIGN

The third major structural design was a folding triangular frame supported by a back leg mounted on a trailer. The top of the A-frame held a sleeve and bearing system that gave the boom arm swiveling ability. This design came out of the desire to make the

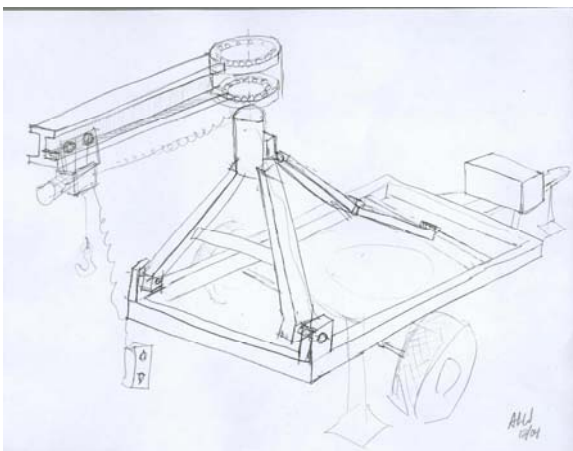

Figure 3.3: Trailer Folding Concept sketch

crane easily collapsible. Figure 3.3 shows an early sketch of this design drawn by fellow classmate Andy Wallner. Notable features of this sketch are the small utility trailer used for the base, the roller-cart for the winch on the boom arm, and the pin joints that allow the crane to collapse. This A-frame design became the basis for our final design.

intrigued by the possibility of working a camera-tripod type idea into our crane design to make it more structurally sturdy. During this design phase we explored trying to automate the swivel and lateral motion of our boom arm by using electric motors and gear systems. The idea was that all crane operation would be able to take place from one control panel that would be integrated into the crane.

4. FINAL PROTOTYPE DESIGN *THE CRANE WHICH WAS BUILT*

OVERVIEW

The design used for the final constructed prototype (Figure 4.1) is very similar to the concept shown already in the sketch of Figure 3.3. This crane, which mounts to a trailer, is fully collapsible and comes apart component-by-component. The crane is primed and painted for corrosion prevention. The major components of this final design can be separated into the following:

- Base
- A-frame
- Back legs
- Swivel Connection
- Boom/Truss/Track
- Winch/Grabber
- Outriggers
- Trailer

The footprint of the base is 4'x8', and the truss is 10' long, giving the crane a 20' diameter reach. It can lift the bottom of the tire to a height of about 7 ½-feet. For detailed drawings and assembly instructions for the entire crane, see Appendix B.

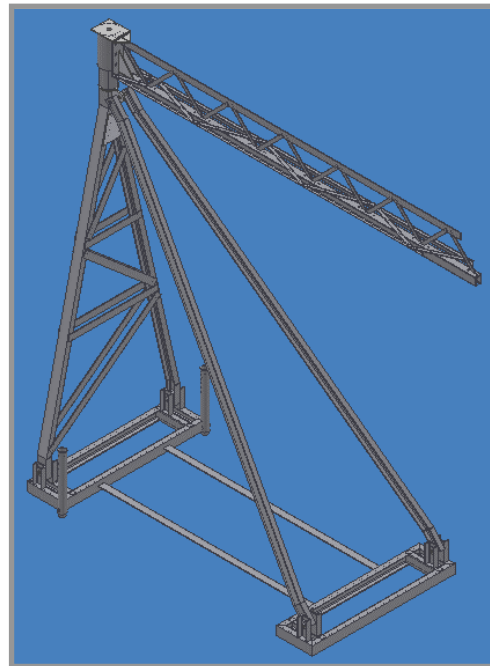

Figure 4.1: Final Prototype CAD model

Some obvious differences between this prototype design and the initial conceptual sketch of Figure 3.3 are the truss boom instead of an I-beam, two solid back legs instead of one folding back leg, and the reinforced A-frame. However, the initial concept is still very much preserved in this prototype.

In the detailed descriptions of the crane components that follow, “front” will refer to the A-frame end of the crane (the left side of Figure 4.1), and “back” will refer to end opposite the A-frame (the right side of Figure 4.1).

BASE

The basic design of the base is two rectangles made of 3-inch channel connected to each other with flat bar (Figure 4.2). The base weighs 180 lb, and can be carried by two people.

DIMENSIONS

Each rectangle of the base is 4' x 1', and is constructed of 4 pieces of C3x4.1

Standard U.S. Channel. Each piece is cut at a 45° at the end, allowing them to be welded together in a rectangle. The

two pieces of flat bar joining the two rectangles are 6-foot sections of 2-inch flat bar, and are welded to the rectangles at the bottom edge of the channel. Connecting the two rectangles guarantees proper spacing of the base, which is important in order for the crane to stand up straight.

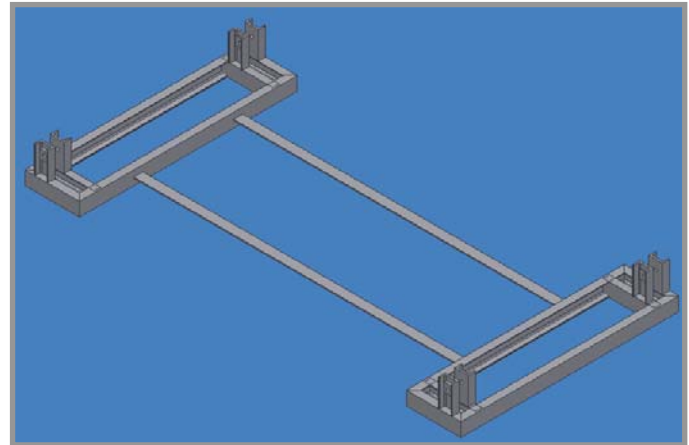

Figure 4.2: Base

The base mounts to the trailer with four bolt plates (two in front, two in back). The plates are welded to the channel, and each plate holds two bolts (See Appendix C.1 for specs on these bolts). The base is symmetrical length-wise and width-wise, so it can be oriented either way on the trailer without affecting the rest of the setup of the crane.

PIN JOINTS

Each rectangle also contains two pin joint supports on which the legs of the crane mount. Each pin joint support is made of two small pieces of C3x4.1 Channel. One piece of the support is welded to the top of the short piece of the rectangle portion of the base, and the second is welded to an extra cross support of C3x4.1 channel that is welded between the two long sides of the rectangle portion (Figure 4.3). The pins used in the pin joints are made of $\frac{3}{4}$ " solid round bar, so each piece of channel has a $\frac{7}{8}$ " hole drilled in it for the pin to slide through. The holes are reinforced with small square pieces that give more surface area on the pin, reducing stress levels in the pin, and thus prolonging its life (See Appendix C.2 for pin joint stress calculations and Appendix D.1 for pin FEA analysis).

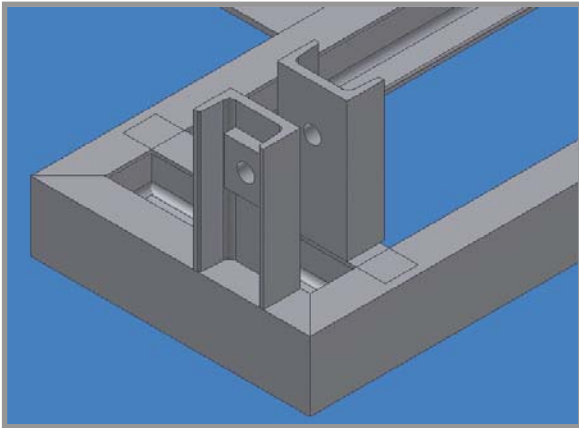

Figure 4.3: Base pin joint support detail.

Originally, the each pin joint support contained only one small piece of channel. After some initial testing, it became evident that a second piece was needed to eliminate the large amount of play in the joint that was present with just one support. Adding the second piece of channel to each joint eliminated much of this play and helped improve the stability of the crane drastically.

A-FRAME

The A-frame (Figure 4.4), the name given to the two front legs of the crane, is responsible for carrying the bulk of the load on the crane. It is constructed from two pieces of heavy 3" channel, and is reinforced by flat bar cross-members. It must resist a large bending moment to either the front or the side when the crane is fully loaded. The A-frame weighs 197 lb, and can be carried by 2 or 3 people.

The channel used for the A-frame legs is C3x6 Standard U.S. Channel. The heavy channel is intended to give the A-frame the necessary resistance to bending under a front or back loading condition (see Appendices C.3 & C.4 for these calculations). The two pieces are welded together to form a box beam shape at the top of the A-frame, and each piece is bent outward below the welds so that the bottoms of the legs are spaced 4-feet apart. This gives the A-frame an overall height of roughly 10-feet. The bottoms of each leg are bent inward to create a vertical portion of leg that can slide between the pin joint supports on the base. Holes are drilled through the bottoms of the legs for the pins to pass through, and these holes are reinforced with square inserts in the same manner as the holes in the pin joint supports on the base (Figure 4.5).

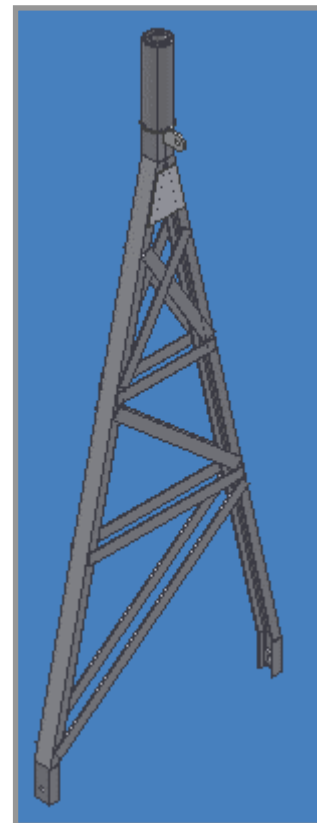

Figure 4.4: The A-frame

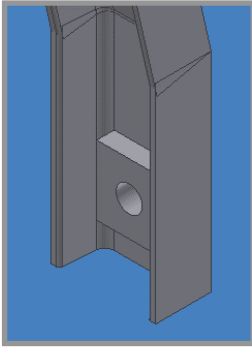

Figure 4.5: Pin joint reinforcement on A-frame leg

The cross bracing on the A-frame is made of flat bar. The triangular shapes formed by the cross bracing gives the A-frame the necessary strength to withstand bending under a side loading condition. The horizontal pieces are made of 3/16" x 2" flat bar, and the diagonal pieces are made of 5/16" x 2" flat bar. Under side loading, the diagonal cross-members carry a larger load than the horizontal ones, hence the thicker flat bar. The required thickness of the flat bar was determined using structural standards of Allowable Stress Design for compression members

(See Appendix D.2 to see FEA analysis and calculations).

The two plates at the top of the A-frame give the top portion of the A-frame (above the cross bracing) the necessary bending strength under a side load. The back of the top of the A-frame also contains a small fin with a hole in it that serves as the pin joint connection point for the back legs (Figure 4.6).

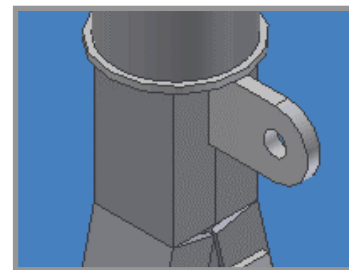

Figure 4.6: Back leg fin pin joint connection

BACK LEGS

The back legs of the crane (Figure 4.7) are made of lightweight C3x4.1 channel, each with two bends near the ends to allow them to align with the pin joint supports on the base and with the pin joint fin on the top of the A-frame. The ends of each leg contains the same type of reinforced pin hole as the A-frame legs and pin joint supports on the base.

The back legs were designed with lightweight channel as opposed to the heavy channel used for the A-frame because they do not experience any bending load like the A-frame. The back legs are pinned at both ends, making them only compression or tension members. In general, if the load is off the front of the crane, the back legs are in tension, and if the load is to the back, the back legs are in compression.

Calculations were done to ensure that the back legs would not

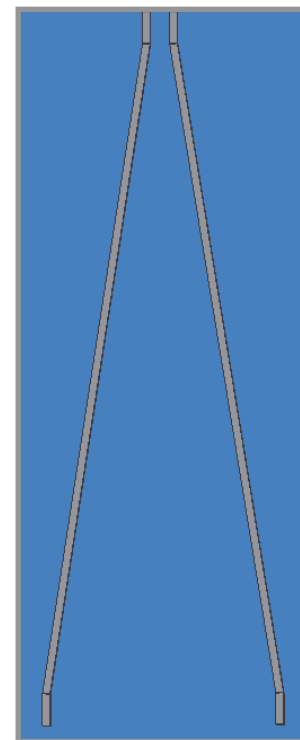

Figure 4.7: Back Legs

be in danger of buckling under the compressive load that they will see (see Appendix C.4 for these calculations).

In the original concept sketch, the crane had just a single back leg with a joint in the middle of it. This joint was to allow the crane to be set up and taken down easily. Theoretically, the cable coming from the winch could have been connected to the hinge, and the winch could have actually pulled this leg straight as a way to raise the crane up. However, since this leg would have been in compression under rear loading, the hinge was determined to be a non-durable design. Furthermore, it was decided that two back legs rather than one would help make the crane more stable.

SWIVEL CONNECTION

The swiveling connection mounts on top of the A-frame, and allows the truss to have 360° rotation. It works by using a sleeve and bearing system. Two pipes of different diameters fit over each other to form the sleeves, and the pipes are separated with bearings.

The basic idea for the design of this system seemed quite simple; a thrust bearing mounted to the top of the inner pipe would carry the downward load from a cap welded on top of the outer pipe, and a radial bearing would fit between the inner and outer pipes at the bottom of the pipes to help counteract the moment caused by the load on the truss. However, this simple setup needed to be tweaked in order for it to actually work, and some extra parts were introduced into the design to make it functional. Calculations for stresses in the swivel connection can be found in Appendix C.6.

The final swivel connection design on the prototype (Figure 4.8) consists of the following components:

A: INNER PIPE

The inner pipe, a size 2 standard pipe, mounts inside of the channel at the top of the A-frame. The top of the pipe is flush with the top of the channel, and the bottom of the pipe goes all the way down to where the legs of the A-frame start to bend outward. The purpose of this pipe is to provide a mounting point for the large bolt and thrust bearing,

D: CAP

A cap made out of a square 1/4-inch thick plate is welded to the top of the outer pipe. A 3/4-inch long piece of size 2 pipe is welded to the underside of the cap to create a mounting place for the bearing housing (the housing can't be directly welded to the cap, because the cap is made of steel and the housing is aluminum). A 1-inch diameter hole is drilled in the top of the cap to allow the 1-inch bolt to pass through out the top of the whole swivel assembly.

E: ROUND PLATFORM

The round platform is a custom part made by Dave Ryskamp on the lathe in the metal shop, and it gives a surface for the thrust bearing to sit on. Its design is a stepped cylinder with a hole through it. The top part of the platform has the same diameter as the outside of the inner pipe, and the bottom part has the same diameter as the inside of the inner pipe; this allows it to sit snug and secure in the top of the inner pipe. The 1-inch hole running vertically through the middle of the platform allows the 1-inch bolt to pass through.

F: THRUST BEARING

The thrust bearing sits upside down in this assembly, meaning that the casing for the bearing is on top of the bearing rather than on the bottom. The casing fits over the small piece of pipe on the underside of the cap, and it is secured to this pipe with setscrews. This was necessary to do because the casing is made out of aluminum, which could not be welded to the steel cap. The casing then sits on the bearing, which sits on top of a round platform mounted in the inner pipe. The bearing fits around the 1-inch bolt to secure it from moving side to side.

G: BOLT

The 1-inch diameter bolt runs up through the middle of the whole assembly, and is capped with a nut on top of the cap on the outer cylinder. The bolt is oriented upside-down, with the head of the bolt actually being welded to the bottom of the round platform inside the inner pipe. The end of the bolt sticks up out of the top of the cap on the outer pipe, allowing the nut to hold the entire top swivel assembly to the crane. The bolt also helps keep the thrust bearing in line.

H: BRASS BUSHINGS

Two radial bushings made of brass fit between the middle pipe and the outer pipe, allowing the outer pipe to swivel around the middle pipe. The bushings are thin brass rings that are press fit into the inside of the outer pipe, one near the top of the pipe and one at the bottom. Using two of them keeps the swivel assembly lined up vertically. They transfer the bending moment caused by the load on the truss from the outer pipe to the middle pipe. Applying a thin layer of grease to the outer surface of the middle pipe allows for easy rotation of the entire assembly.

BOOM

The boom (Figure 4.9) on top of the crane is 10-feet long, giving the crane a 20-foot diameter circular reach. It is designed to withstand bending under a straight downward load and under a side load, which is present when someone pulls the boom around to make the truss swivel. To give it strength in both of these directions, the main structure of the boom is actually made up of two separate flat trusses that are laid through each

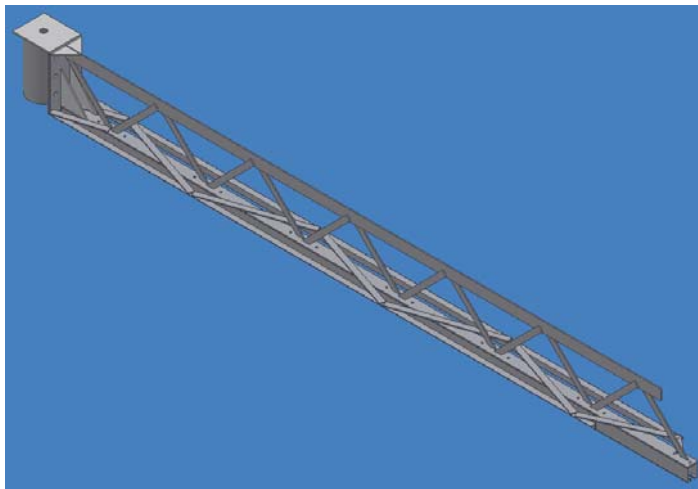

Figure 4.9: Boom truss structure and roll track (shown mounted to swivel connection)

other and welded together. This gives the overall truss a cross section of an upside-down T. The vertical part of the T gives the boom strength under vertical loading, and the horizontal part of the T gives the boom strength under side loading.

Overall, the boom weighs about 80 lb. without the top swivel assembly attached to it.

TRUSS

The truss portion of the boom is made out of flat bar and angle iron. The vertical portion of the truss is build from two 10-foot sections of 2-inch flat bar joined with thirteen small angled pieces of 1-inch flat bar. The bottom piece of flat bar on the vertical portion of the truss lays down flat and is drilled with thirteen bolt holes that allow it to hold the roller track in place. The horizontal portion of the truss consists of two 10-foot sections of 1-

inch angle iron joined by eight angled pieces of 1-inch flat bar. These flat bar cross members of the horizontal truss are welded to the bottom piece of flat bar of the vertical truss. Under side loading, the angle iron on one side of the truss is put into compression and it must not buckle. Calculations on the angle iron were done using structural standards of Allowable Stress Design for compression members. FEA analysis was done on the entire truss to test its stress levels and deflections (see Appendix D.3 for FEA results and buckling calculations).

ROLL TRACK

The roll track is located along the bottom of the boom, and it allows the winch (and thus the tire being lifted) to be moved in and out along the boom. The track and matching roller carts were purchased at Menard's, and are actually designed for use in a sliding barn door system. The roll track is 10-feet long, and is made out of 1/16-inch galvanized steel. Thirteen holes are drilled in the top of the track to allow it to be bolted to the bottom piece of flat bar of the truss. For calculations on these bolts and the strength of the track, see Appendices C.7 & C.8, respectively.

PLATE CONNECTION

The truss connects to the swivel connection through two plates that bolt together (Figure 4.10). One plate is welded to the end of the truss with a system of gussets that create enough weld area for the welds to withstand the load of a tire and a side load (see Appendices C.9 & C.10 for these weld calculations). This plate bolts to another identical plate, which is welded to the swivel connection (see Appendices C.11 and C.12), with six ½-inch bolts. The top two bolts of these six are grade 5 bolts, because they carry a greater amount of load than the other 4 bolts (see Appendix C.13 for these bolt calculations).

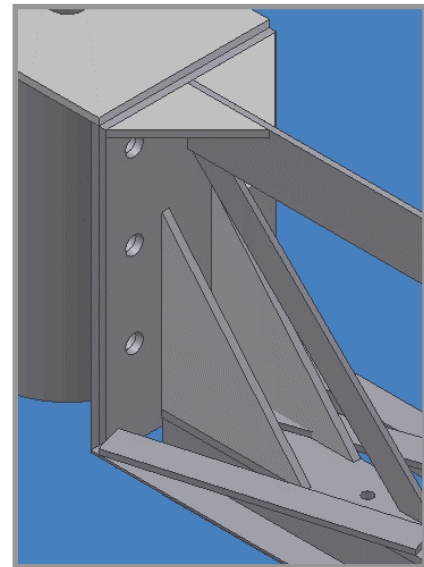

Figure 4.10: Boom gusset and bolt-hole detail

WINCH AND GRABBERS

The winch and grabbers work together to actually lift the tires up in the air. The winch, which is an electric hoist rated at 880 lb and purchased at Harbor Freight Tools, can roll



Figure 4.11: Grabber photograph

up and down the roll track on small bearing carts. The winch is attached to these bearing carts with two bolts, for which calculations can be found in Appendix C.14. A bolt across the end of the roller track acts as a stop that prevents the winch from being able to roll off the end of the track and crash to the ground.

The grabbers are made out of bent 7/8" steel bar stock so that they will not deform while lifting a tire (see Appendix C.15 for grabber bending calculations). Each grabber is formed by making a series of bends in a long piece of this stock. First, a 30° angle is bent in the middle of the bar to form the top bend of the grabber. Next, each end is bent out to an angle of about 60° to form the fingers that grip underneath the tire. Finally, the top of the grabber (where the first bend was made) is bent inward slightly so that it can wrap around the top of the tire. Two grabbers can be connected together with chain or a tow strap that hangs from the hook on the winch cable. The fingers hook underneath the sidewall of the tire, and as the winch lifts the grabbers, the high level of friction between the fingers and the tire holds the tire and the grabbers in place. This friction is caused by the angle of the fingers, which causes them to dig into the rubber of the sidewall. To get the fingers underneath a packed tire that is sitting on the ground, 1 or 2 people must briefly lift up one side of the tire while the grabber is put into place.

OUTRIGGERS

In order to get the weight of the tire off the suspension of the trailer, outriggers were designed to fit onto the trailer. To set the outriggers, the tongue of the trailer can be lowered, the outriggers can be dropped down to the ground, and then the crank on the tongue can be used to re-level the trailer bed.

The design of the outriggers consists of two standard steel pipes that fit over each other, each with holes that can line up with each other. The outer pipe, a size 2 pipe, has one set of holes, and the inner pipe, a size 1 ½ pipe, has multiple holes that make its height

adjustable. When the desired height of the outrigger is achieved, a pin fits through the holes of both pipes. A plate is welded to the bottom of the inner pipe to increase surface contact area with the ground on which the outriggers will sit. Braces were fabricated in order to attach the outriggers to the trailer just behind the wheel wells.

TRAILER

The trailer on which the prototype is mounted is a double-axle 16' long x 7' wide utility trailer with a 1-foot high railing on three sides. It was delivered on February 11th by friends of James Kuiper who were driving a van back to Michigan from New Mexico. The trailer was power-washed and then placed in the Engineering Building so that fabrication of the crane could begin on it.

Some modifications were made to the trailer in order to make it more functional for holding the crane. In order to bolt the crane easily to the trailer, nut plates were mounted to the bottom of the wood on bed of the trailer. Holes were predrilled to line up with the nuts in these plates. This allows the crane mounting bolts to be removed or installed very quickly by only one person once the base is set in place (See Appendix C.1 for calculations on these bolts). The wooden planks that make up the bed of the trailer were not initially anchored down well enough to securely hold the crane. Whenever the crane is loaded, it relies on these wooden planks to keep it from tipping. However, these planks would bow up every time the crane was loaded, so bolts were added to anchor them down to the frame of the trailer. Finally, the bed of the trailer was painted.

5. TESTING AND DESIGN CHANGES

IMPROVEMENTS THAT WERE MADE AND SHOULD BE MADE

OVERVIEW

Many of components of the prototype reached their final design through testing that took place as the prototype was being built. Tests done on the crane while it was being built pointed out weak spots of the design that needed attention. These weak spots were redesigned and rebuilt on the prototype. The final prototype design works well, but there were still a number of important improvements that could have been made to the design

beyond just those that are found in the final prototype. The Theoretical Future Design Changes section below highlights some of those changes that we feel would be necessary in order to make the crane durable enough to actually build an entire Earthship.

TESTING INDUCED PROTOTYPE CHANGES

Once the initial version of the prototype was built, we began testing it for functionality to find the trouble areas.

SWIVEL CONNECTION FAILURE

The original design for the swivel connection failed in bending under testing. This design required the small pipe to hold the entire bending moment from the truss, and it could not do this. An error had been made in a calculation that allowed the stress in this pipe to be overlooked. The calculation error was found before a fully load test was performed, so when the test was performed, the failure was expected. We attempted to lift a 400 lb concrete block with the crane, and as expected, the top pipe bent severely.

Two major options were considered for redesigning the swivel connection. The first option was to design a pre-tensioned cable system around the truss to support it and distribute the load on the truss to the A-frame rather than to the pipe. This idea came out of researching how large industrial cranes worked. We learned that these cranes often use pre-tensioned cables and large counterweights. For example, one crane we found that had a 20-ton lifting capacity also used an approximately 20-ton counterweight off the back. On this principle, our crane, which was designed to lift approximately 500 lb, would use an approximately 500 lb counterweight, which clearly was not feasible for this project. This made the cable pre-tensioning system rather difficult to design. The calculations from our attempt at doing so can be found in Appendix E.1.

The second major option, which turned into the final design, was to simply add a larger pipe to the top connection. Along with the larger pipe, the channel of the A-frame was extended up through the entire pipe, and the old small inner pipe was also placed inside the channel. These three pieces together created a large enough moment of inertia to withstand the 5000 ft-lb bending moment on the top connection.

TRUSS REDESIGN

As seen back in the original design concept sketch (Figure 3.3), the original idea for the boom of the crane was an I-beam. In order to save weight, the I-beam idea was traded in for a simple truss design. The original truss design used a small trussed up T-beam. However, this design idea was derailed once our steel order came in with an I-beam instead of the T-beam that we had ordered. The I-beam was simply too heavy to use for our boom, so we were forced to quickly design a new truss. The new design, made entirely out of flat bar, used 2" flat bar for the base and short pieces of 1" flat bar as truss element angling up to another piece of 2" flat bar that ran along the top (Figure 5.1). This design was 9.75-inches tall and 2-inches wide, and it worked well in Algor FEA simulations of simple downward loading.

When the crane was first assembled for initial testing, Professor DeRooy brought to our attention his concern about the lateral stability of our truss. He envisioned the truss taking a large side load when people were swiveling the truss around, larger than what the truss had been designed to handle. After some simulation runs on STAADPro and Algor that showed DeRooy's

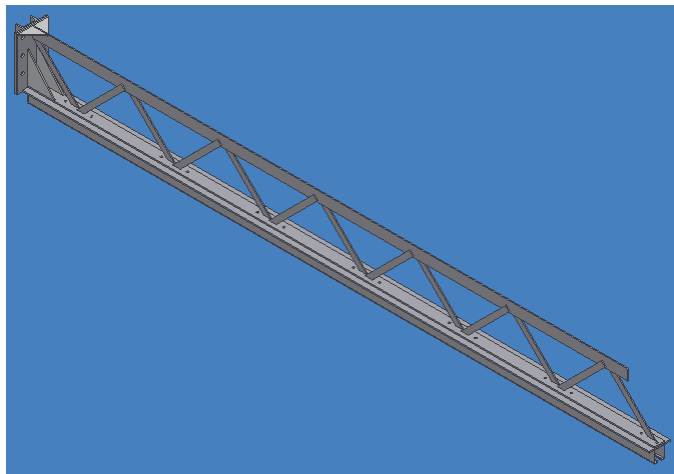

Figure 5.1: Original truss design

concerns to be legitimate, the truss design was modified to be able to withstand the side loading. This essentially involved building a second truss that lies horizontally across the bottom of the existing truss. The added truss elements were again made from 1-inch flat bar, which was the most readily available material. The long elements of this second truss were made from 1-inch angle iron, which was also readily available. The angle iron provides adequate resistance to buckling in the case of large side load. This was the final design described in section 4 that was used for our prototype.

A-FRAME BRACING

Once our redesigned swivel connection and truss were designed, constructed, and were operational, testing continued. It was known from some rough calculations that the A-frame would probably experience high levels of stress under side loading, and as

expected, they did. The legs visibly deflected simply from a person pulling down on the end of the truss when it was turned to the side. The solution to this problem was to add angled cross bracing to the A-frame as discussed in Section 4.

THEORETICAL FUTURE DESIGN CHANGES

Though our prototype works ok, it could be improved by the following simple design changes.

A-FRAME

While the cross bracing on in the A-frame on our prototype makes it very rigid under side loading, it is still not completely satisfactory under front and back loading. With a static 500 lb load, the A-frame bends elastically a little bit, which is not a huge issue.

However, when the winch lifts a tire up, it starts and stops with a rather large jerk, creating a dynamic loading situation. This level of loading could potentially elevate stress levels in the A-frame into the plastic region of deformation, which would slowly cause the crane to become less functional. If the A-frame were to fail in this mode, it would at least do so in a “safe” manor—it would gradually sag over time rather than suddenly crack off and fall.

The proposed design improvement to the A-frame is to build it out of light weight C5x6.7 Standard Channel rather than the C3x6 channel used for the prototype. The 5-inch channel has a much higher moment of inertia to resist frontward and backward bending, and it weighs less than a pound per foot more than the heavy duty 3-inch channel currently in use. 5-inch channel will give the A-frame a more satisfactory safety factor than that of the prototype (See Appendix E.2 for these calculations).

SWIVEL CONNECTION

In order to change the A-frame to 5-inch channel, the pipes on the top connection must also be enlarged. This change also boosts the strength of the top connection considerably over the prototype design (see Appendix E.3). The middle pipe must be a size 6 standard weight pipe, and the outer pipe must be a size 7 standard weight pipe. The size-6 pipe fits over the two pieces of 5-inch channel if the corners of the channel are ground down slightly, and the size-7 pipe fits over the size-6 pipe with a ½-inch gap between them in which new brass bushings can fit.

Another change involving the swivel connection that should be made would be to extend the middle pipe all the way down to the bottom of where the legs bend outward, and then mount the fin on the pipe. This would eliminate any potential bending issues at the top of the A-frame.

TRUSS DESIGN

The prototype truss works for testing purposes, but a better design could be fabricated for long term durability. This design would involve making the cross section shape of the truss a triangle (Figure 5.2) rather than the upside-down T-shape of the prototype truss. This would allow the truss to take loads both vertically and horizontally with a high level of rigidity. This design could be fabricated by using the original truss design (Figure 5.1), replicating it two more times, and then welding the three together in a triangle to make one truss of optimum strength and shape.

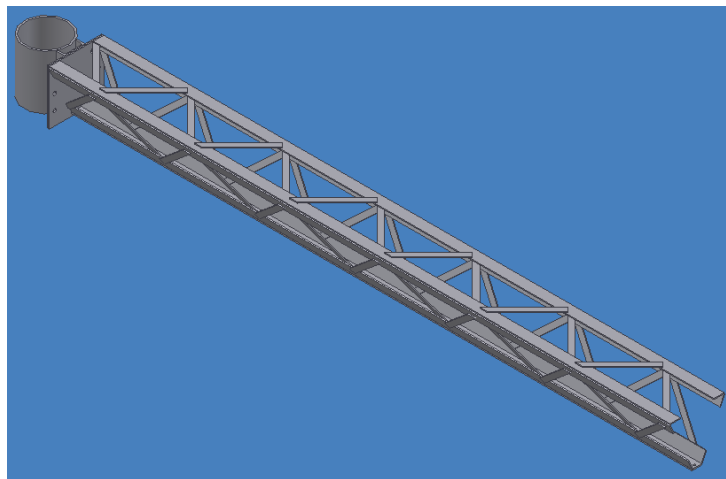

Figure 5.2: Theoretical triangle truss design

OUTRIGGERS

A problem arose with the placement of the outriggers relative to the crane itself on the trailer bed. Essentially, they are between the A-Frame and the suspension on the trailer, when ideally the A-Frame would be between the outriggers and the suspension. This causes a problem when the load is put directly off the back end of the trailer since it tends to tip under a full load. To remedy this situation, since the current position of the outriggers is the only practical one, the crane should be moved a couple of feet towards the middle of the trailer. This change coupled with the tire packer sitting on the front (250 lb) should allow the outriggers to work effectively without the trailer tipping.

6. BUDGET

HOW MUCH DOES IT COST?

When a project is planned, a budget is vital to controlling how money will be used through the course of it. The engineering department initially provided us with about \$300 for use on our projects. Since a lot of teams don't actually use most of their budgets (i.e. civil teams that are not constructing a prototype), that amount can be increased to around \$500 for teams that are spending a lot of money. We were one of those teams spending a lot of money, because our prototype is large.

Table 6.1 outlines all of our expenses for the year. It includes the date, item, vendor, and price.

Table 6.1: Actual Yearly Budget

Date	Description	Vendor	Cost
29-Nov-04	Shaft	Post Revolution Project	Free
29-Nov-04	Thrust Bearing	Post Revolution Project	Free
29-Nov-04	Radial Bearing	Post Revolution Project	Free
1-Feb-05	880lb Winch	Harbor Freight	\$80.00
18-Feb-05	10ft roller track + Bearings	Menard's	\$50.00
22-Feb-05	All Needed Steel	Genzink Steel	\$300.00
22-Mar-05	Bolts, washers, and nuts	Menard's	\$10.41
29-Mar-05	Bolts and Nuts	Lowe's	\$5.05
30-Mar-05	Bolts and Nuts	Lowe's	\$8.09
14-Apr-05	Steel Tube	Central Steel and Iron	\$4.24
14-Apr-05	Nuts, bolts, washers	Menard's	\$5.84
19-Apr-05	Bolt	Lowe's	\$1.10
26-Apr-05	Nuts and bolts	Menard's	\$2.12
Total:			\$466.85

As you can see above, we managed to stay within the projected budget. However, it must be noted that due to our limited negotiating skills, we ended up paying \$300 for our steel, while most teams were able to get their steel completely donated. If that had been the case for us our expenses would have been dramatically reduced.

So what if our crane gets to New Mexico and the concept really catches on? Perhaps someone will want to reproduce our crane. Before they do this they might consider that they won't get the same donations and discounts that we did this year. Table 6.2 shows how much it would cost to build our crane from scratch without any discounts or donations.

Table 6.2: Total Rebuild Cost (At Cost)

Description	Vendor	Cost
Thrust Bearing	Unknown	\$30.00
Brass Rings	Unknown	\$9.00
880lb Winch	Harbor Freight	\$160.00
10ft roller track + Bearings	Menard's	\$50.00
All Needed Steel	Genzink Steel	\$1,000.00
Bolts, washers, and nuts	Menard's	\$10.41
Bolts and Nuts	Lowe's	\$5.05
Bolts and Nuts	Lowe's	\$8.09
Steel Tube	Central Steel and Iron	\$4.24
Nuts, bolts, washers	Menard's	\$5.84
Bolt	Lowe's	\$1.10
Nuts and bolts	Menard's	\$2.12
Total:		\$1,285.85

Since we are suggesting the construction of a new and redesigned prototype, there will be a cost incurred to modify it. Of course most of our crane components can be reused if construction of the other components is done carefully. The trailer is obviously retainable along with the entire base and the back legs. The A-Frame and truss will need to be rebuilt entirely unless someone plans on grinding a lot of full welds. Table 6.3 outlines which components can be reused and which will have to be purchased to give a total modification cost for our current prototype.

Table 6.3: Total Modification Cost

Description	Vendor	Cost
--------------------	---------------	-------------

Thrust Bearing	Unknown	Reuse
Brass Rings	Unknown	Reuse
880lb Winch	Harbor Freight	Reuse
10ft roller track + Bearings	Menard's	Reuse
All Needed Steel	Genzink Steel	\$500.00
Bolts, washers, and nuts	Menard's	\$10.41
Bolts and Nuts	Lowe's	\$5.05
Bolts and Nuts	Lowe's	\$8.09
Steel Tube	Central Steel and Iron	\$4.24
Nuts, bolts, washers	Menard's	Reuse
Bolt	Lowe's	Reuse
Nuts and bolts	Menard's	Reuse
Total:		\$527.79

More than half of the cost is dropped due to reusing a lot of the current prototype parts. We feel that we kind of let our budget run away a bit at the end, and we weren't careful when estimating how much paint we'd need winding up paying more than necessary. However, we feel that \$500 is a manageable amount of money for a community to come up with to modify our prototype into a crane that will perform how we originally intended.

7. SCHEDULE

HOW LONG DID IT TAKE?

As most engineers know, it would be a very difficult task to accomplish a project of any decent size without some sort of plan of action. In this senior design course we were taught how to effectively plan our projects into a complete schedule by breaking the project into many specific tasks and then allotting a certain amount of time to each task. For our project, we had a start date, an end date, and a project goal. We had to figure out how to accomplish our project goal between the start and end dates. First, we broke our project down into several key areas such as documentation, research, design work, construction, testing, and end of year preparation. From there, we could break down each key area into key tasks specific to that area. One example would be how we broke down end of year preparation into the three tasks of writing the operation and construction manual, writing the final design report, and preparing the final presentation. Altogether, projected over the course of the entire academic year, we came up with 107 key tasks to accomplish in order to finish our project and the requirements of the course.

Since the project schedule is constructed at the beginning of the year, the time allotted to each task is a rough estimate. Since we had never, as engineers, undertaken a project so large that lasted such a long period of time, we didn't really have any experience in judging how much time it would take to accomplish the tasks that we had never done before. It was because of this that Terry specifically allotted over three weeks at the end of the year simply as overflow time for misjudged time budgeting. And as it turned out, those three weeks became very valuable time as we operated slightly behind schedule for most of the year, partially due to a few gigantic setbacks in the construction and testing phase. We realized that such a thing as constructing a project schedule will become easier as experience with project and schedule construction increases over time.

In order to judge our efforts at the beginning of the year, it was useful to make a comparison between our projected schedule and our actual schedule. This is more difficult than it sounds, because our original schedule was constructed with an additional team member that we no longer have. This loss affected our design, and many of the tasks from the beginning of the year became obsolete. Despite this, it is still practical to compare some of the major milestones between our projected and actual schedules.

The first major milestone in our projected schedule was to accomplish a significant amount of research for our project. The reason for this preliminary research was to figure out how feasible our project was and to get some rough sizing on components such as required motor horsepower to size a motor or winch for lifting, or packing a tire to get a feel for the size and weight that our project would ultimately be lifting. We had projected to be finished with our preliminary research by the end of October, and according to our records, we were on track with our original schedule at that point.

The next major milestone was to make our design decision. This did not mean to have our machine completely designed, but meant to have the type of machine clearly decided so that we could easily transition to the actual design phase. This was the next step after research, and we also completed this task on schedule.

The biggest allotment of time in our project, not surprisingly, was devoted to design work. We had originally allotted from November to January (excluding most of December for Christmas Break) to finish the design of our crane. It turned out that, due to an

infinitely improvable concept and a major design failure in April, we ended up doing design work over the course of almost the rest of the year. This didn't turn into a big problem, although we did use most of our extra three weeks to account for design time lost in redesign after the failure, but we felt that it was mostly just an oversight due to our lack of experience with actual design of a product. CAD work was also included in this area of our schedule, and we did a pretty good job of expecting this to be spread out over a long period of time. However, like design, it ended up lasting for longer than expected due to the frequent updates from redesign phases. In fact, in order to fully complete this report, some new drawings had to be made. So a lesson learned would be that CAD work is spread out over the entire duration of the project, and that is not a problem or inefficiency, but simply a necessity since most products change in design over the lifetime of the project to develop it.

The next significant portion of our product development was the actual construction phase. Surprisingly, with a design failure and a couple of delayed steel orders, our construction time was allotted fairly well, taking about as long as we originally thought it would, but because of the above problems, was about two weeks delayed.

The next major task was testing our final prototype. This turned out to be way over budgeted in our original schedule, which was a blessing since we were way behind at this point. Originally, we had allotted over 20 hours for testing our prototype, when in actuality, it only took a couple of hours on different occasions to do all the testing we needed.

The last portion of our schedule was budgeted for preparation for the end of the year. Because we are actually in the middle of that portion right now we can't be sure exactly how long it is going to take to finish everything off, but a solid guess would be that it will be finished within the allotted time, on par with our original schedule.

The experience we gained by scheduling our project tasks from the beginning of the year to the end will be very valuable for our careers as engineers as we will be entering the work force with some idea of how long to expect certain tasks to take and which ones are more likely to take longer than expected. We feel that we did a pretty good job of estimating durations of tasks and also a decent job at staying on schedule despite the setbacks that occurred over the course of the year.

8. CONCLUSIONS

AND IN THE END . . .

During this senior year we participated in two senior design courses (ENGR 339 and 340). Our main assignment was to manage a year long project where we would design and build a prototype to achieve our project goal. We made a schedule and tried our hardest to stick with that schedule. We managed and operated within a small budget and planned our design and construction phase around it. We worked as a team of three to accomplish our goal by effectively recognizing and utilizing each other's strengths and weaknesses. When it was time to buckle down and push for the finish, we did, and we did it with quality and efficiency. Over the course of the year, all of these things contributed to the greatest learning experience we could possibly hope to get out of an engineering program. We now have experience in all of these areas that we didn't have before and this will be very effective in contributing to our success after we leave Calvin College and start lives of our own. We have also learned how to design from a Christ-centered worldview and how to spread this paradigm to hopefully all reaches of the earth. Overall, we feel that we have successfully produced a prototype that demonstrates a good concept. It can and will be improved before being put to use. We are proud of the work that we have done this year, and are eager to apply our newly gained knowledge to our lives after graduating from the Calvin College Engineering Program.

APPENDIX TABLE OF CONTENTS

A. PROTOTYPE PHOTOGRAPHS	38
B. TECHNICAL DRAWINGS	41
B.1: PROTOTYPE CRANE ASSEMBLY AND START-UP MANUAL	41
B.2: TECHNICAL DRAWINGS OF FUTURE CRANE DESIGN	44
C. PROTOTYPE DESIGN MATHCAD CALCULATIONS	61
C.1: BASE ANCHOR BOLTS	61
C.2: PIN JOINT STRESS	63
C.3: FRONT LOAD REACTIONS AND BENDING	65
C.4: BACK LOAD REACTIONS AND BENDING	68
C.5: SIDE LOAD REACTIONS AND BENDING	71
C.6: SWIVEL CONNECTION BENDING	73
C.7: ROLL TRACK BOLTS	75
C.8: ROLL TRACK BENDING	76
C.9: TRUSS WELDS VERTICAL LOADING	77
C.10: TRUSS WELDS SIDE LOADING	81
C.11: OUTER PIPE WELDS VERTICAL LOADING	85
C.12: OUTER PIPE WELDS SIDE LOADING	87
C.13: TRUSS CONNECTION BOLTS	89
C.14: WINCH BOLTS	92
C.15: GRABBER BENDING STRESS	93
C.16: BACK LEG FIN WELDS	94
D. PROTOTYPE DESIGN FEA AND MDSOLIDS SIMULATIONS	96
D.1: PIN JOINT STRESS	96
D.2: A-FRAME CROSS MEMBER STRESS	98
D.3: TRUSS	102
E. THEORETICAL FUTURE DESIGN MATHCAD CALCULATIONS	104
E.1: CABLE PRE-TENSIONING SYSTEM	104
E.2: A-FRAME BENDING FRONT AND REAR LOAD	107
E.3: SWIVEL CONNECTION BENDING	110

APPENDIX A: PROTOTYPE PHOTOGRAPHS



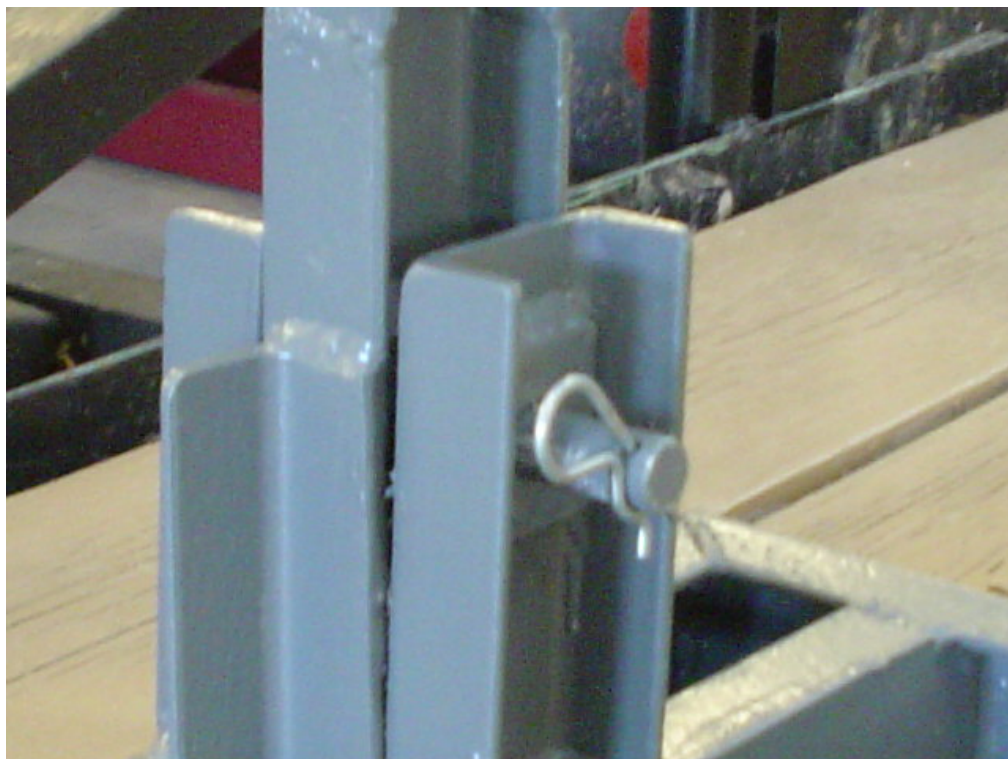



APPENDIX B: CRANE DRAWINGS

APPENDIX B.1 --- PROTOTYPE CRANE ASSEMBLY AND START-UP MANUAL

Step 1) Level the trailer by lowering the front and putting the back outriggers down and then raise the front back up.

Step 2) Bolt the base frame to the trailer using pre-drilled holes

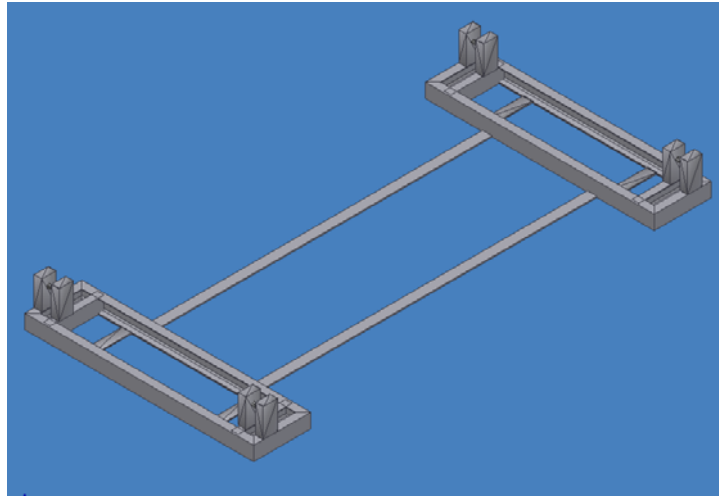

Step 3) Attach the A-frame to the base at the back of the trailer. The connection should be made using the two pins provided. The pinning bracket at the top of the A-frame should be towards the trailer at this point. Make sure the A-frame is securely connected to the base before moving on to step 3.

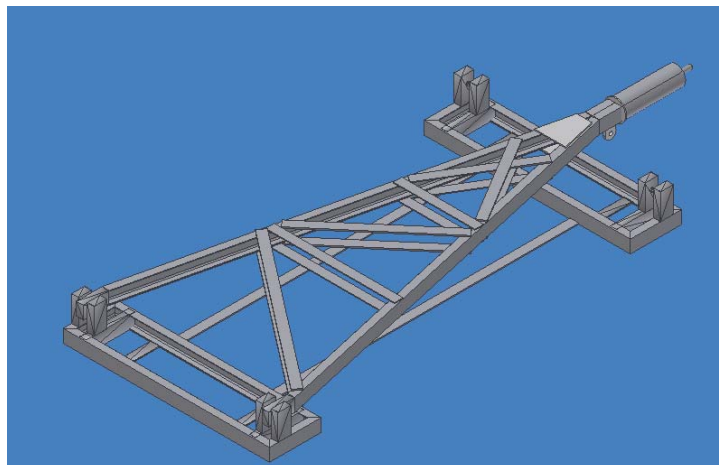

Step 4) Attach the back legs to the A-frame using the pin provided. It may be helpful at this point to set the top of the A-frame on a block so as to have it elevated approximately three feet.

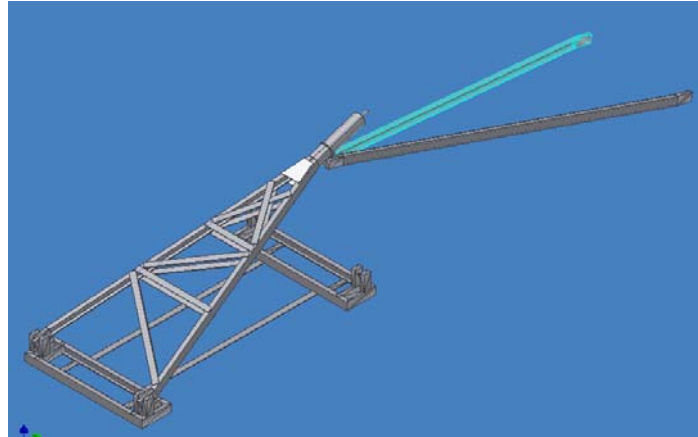

Step 5) Put the winch on the roll track. After the winch is on, put the bolt back that is in the end of the track. This bolt keeps the winch from being able to roll off the end of the track when in use.

Step 6) Slide the truss onto the A-frame. The bolt on the A-frame should fit through the hole in the top of the truss connection. Put the nut tightly on the bolt.

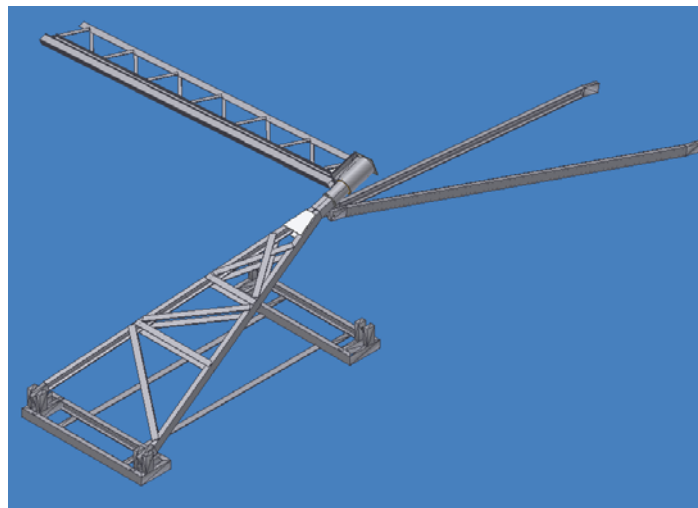

Step 7) Raise the A-frame up to the vertical position and pin the back legs in. Be careful to guide the truss while moving the A-frame into position.

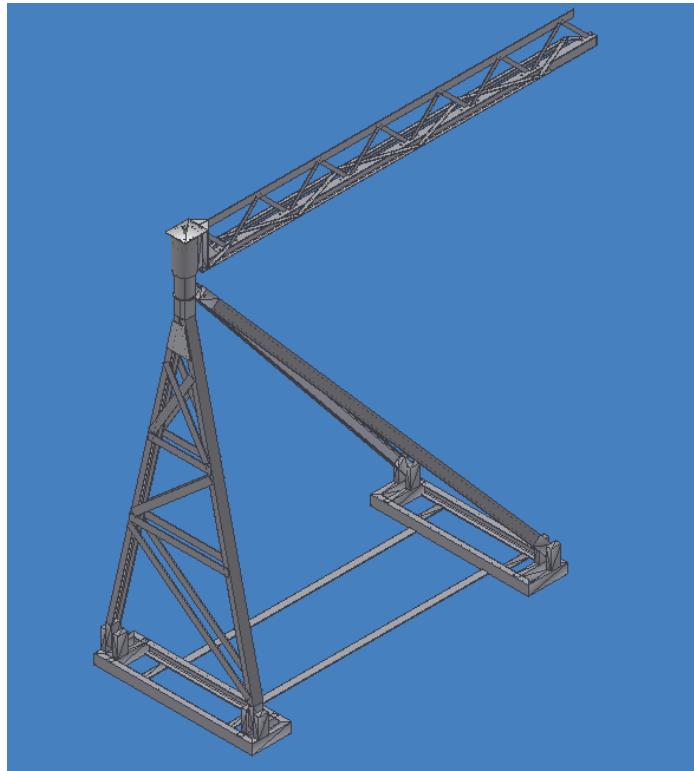

Step 8) Place a packed tire or some other object of 300 or more pounds on the front of the trailer as a counter-weight and make sure all connections are tight and that the trailer is stable.

Step 9) Begin the use of your crane

APPENDIX B.2: TECHNICAL DRAWINGS OF FUTURE CRANE DESIGN

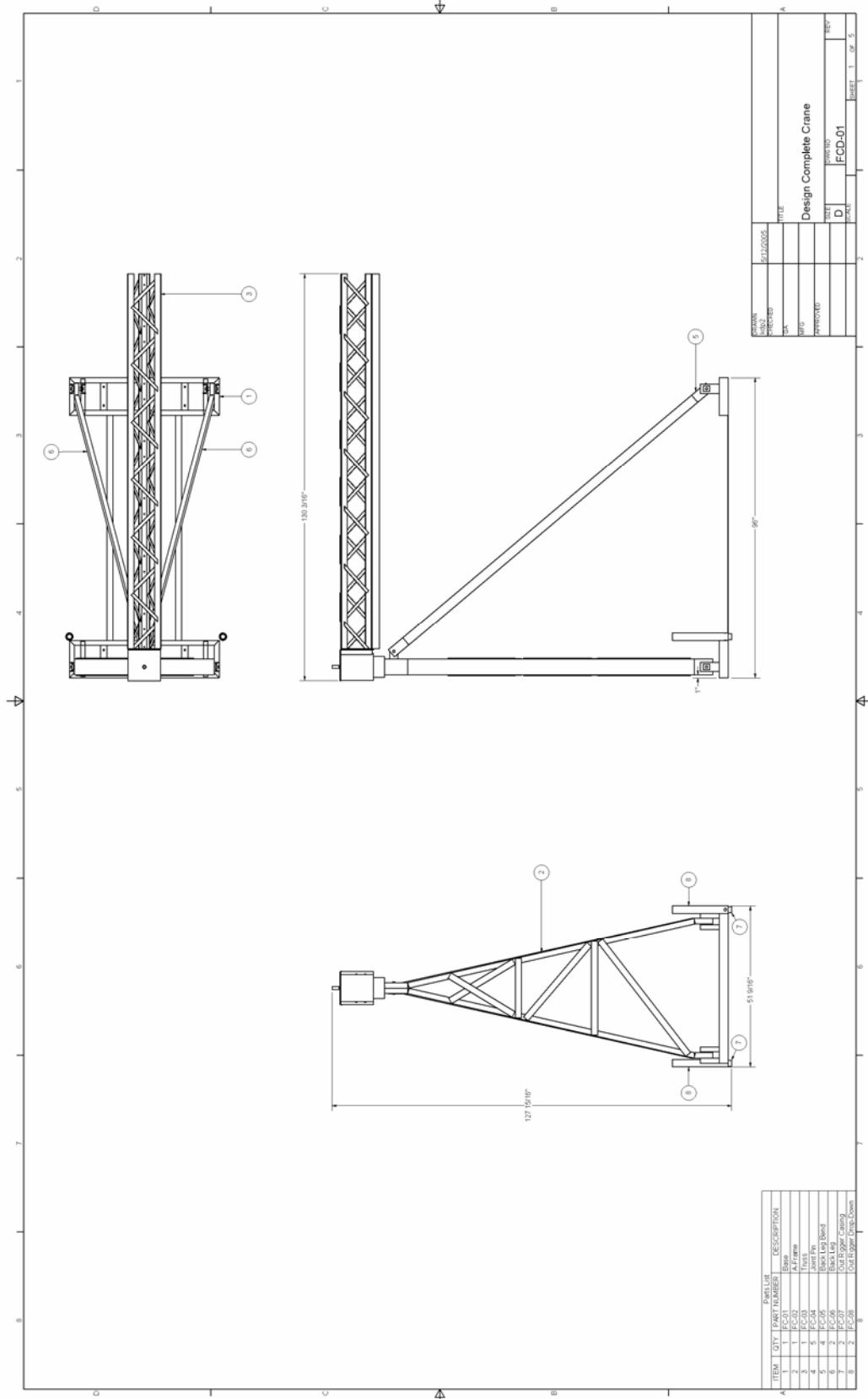

DESIGN NO.	01770005
TITLE	Design Complete Crane
DATE	
BY	
CHECKED BY	
SCALE	1" = 10'
PROJECT	FCD-01
SHEET	1 OF 3

ITEM	QTY	PART NUMBER	DESCRIPTION
1	1	FC-01	Crane
2	1	FC-02	A Frame
3	1	FC-03	Truss
4	1	FC-04	Truss
5	1	FC-05	Truss
6	1	FC-06	Steel Leg
7	2	FC-07	Out Rigging
8	1	FC-08	Out Rigging

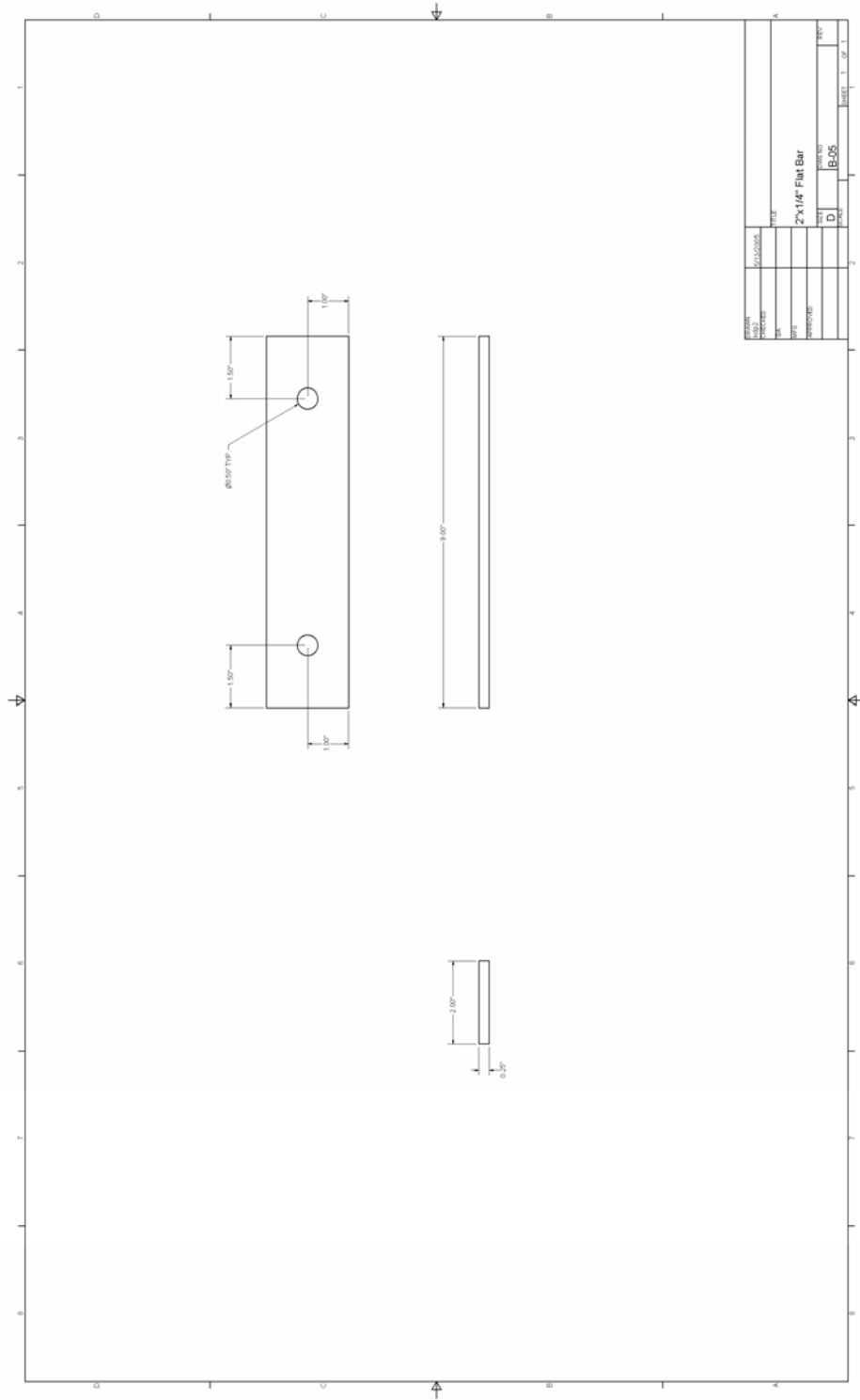

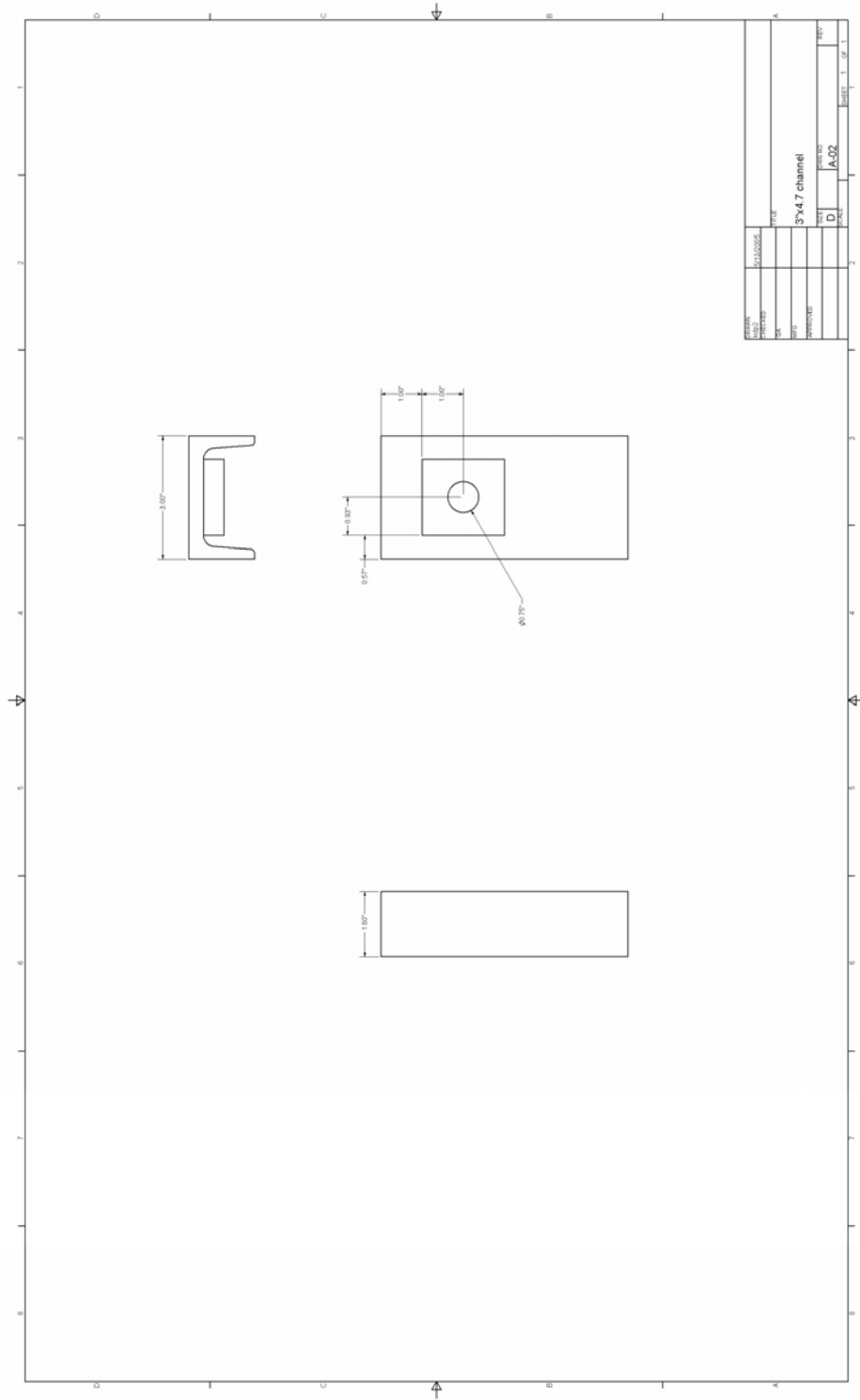

DESIGNER	DATE	SCALE	PROJECT
REVISOR	REVISED	REVISED	REVISED
APPROVED	DATE	DATE	DATE
TITLE		3x4.7 channel	
DRAWN		A.G.	
CHECKED		1.00"	

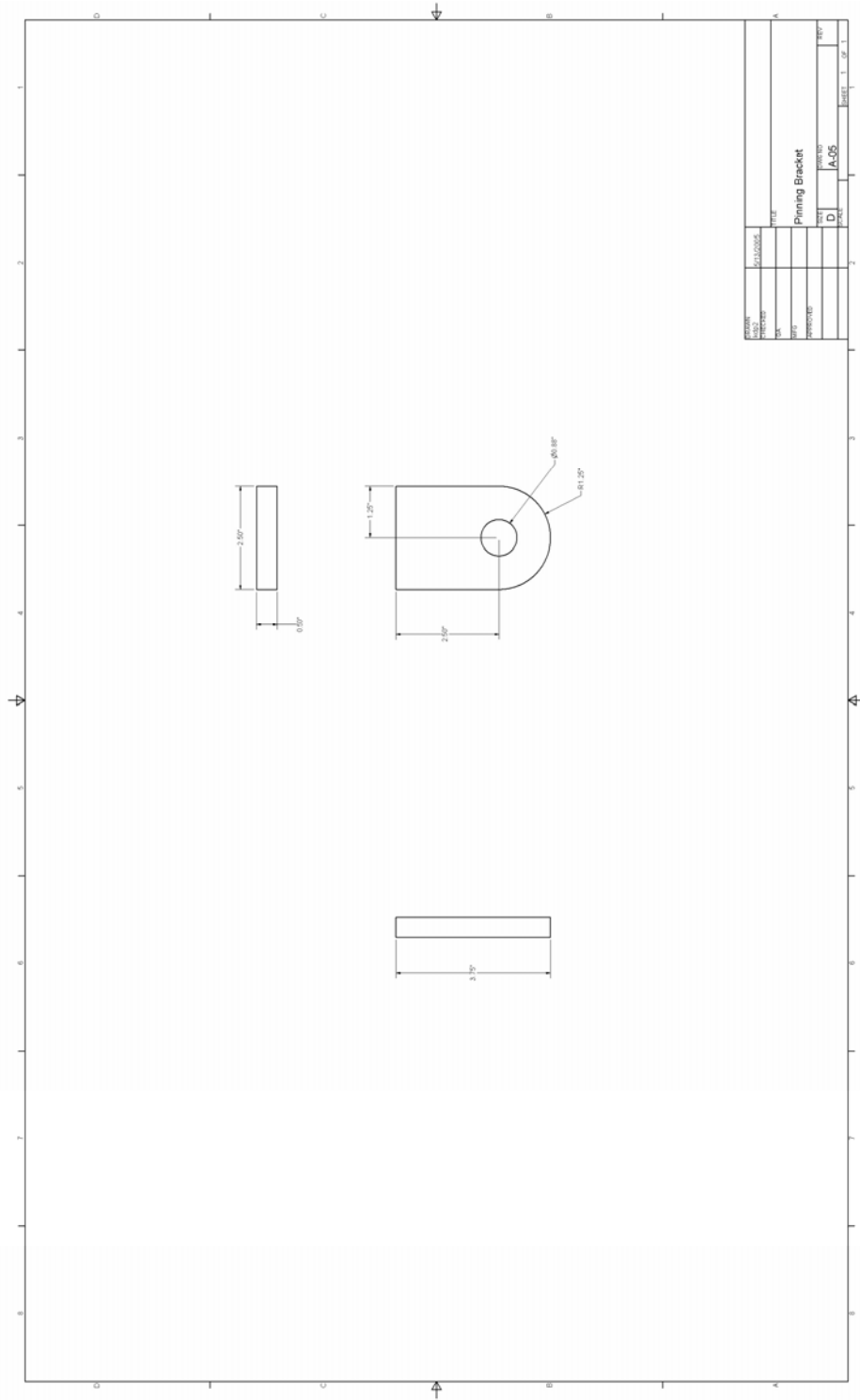

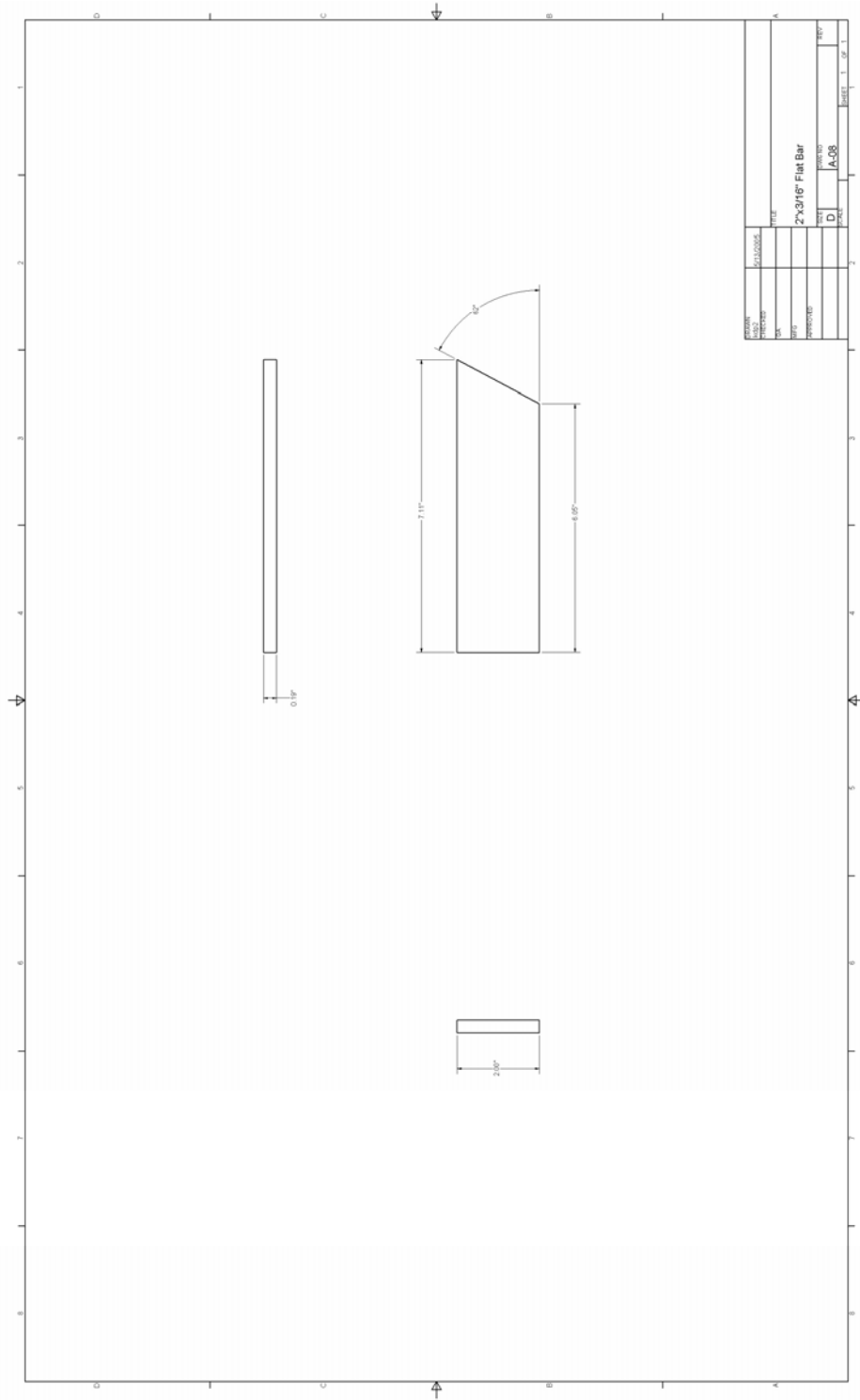

DESIGNER	DATE	SCALE	PROJECT
DR	10/10/08	1:1	2x3/16" Fillet Bar
CHECKED			
APPROVED			
DATE	BY	DATE	BY
10/10/08	DR	10/10/08	DR
PROJECT		SHEET	
2x3/16" Fillet Bar		1 of 1	

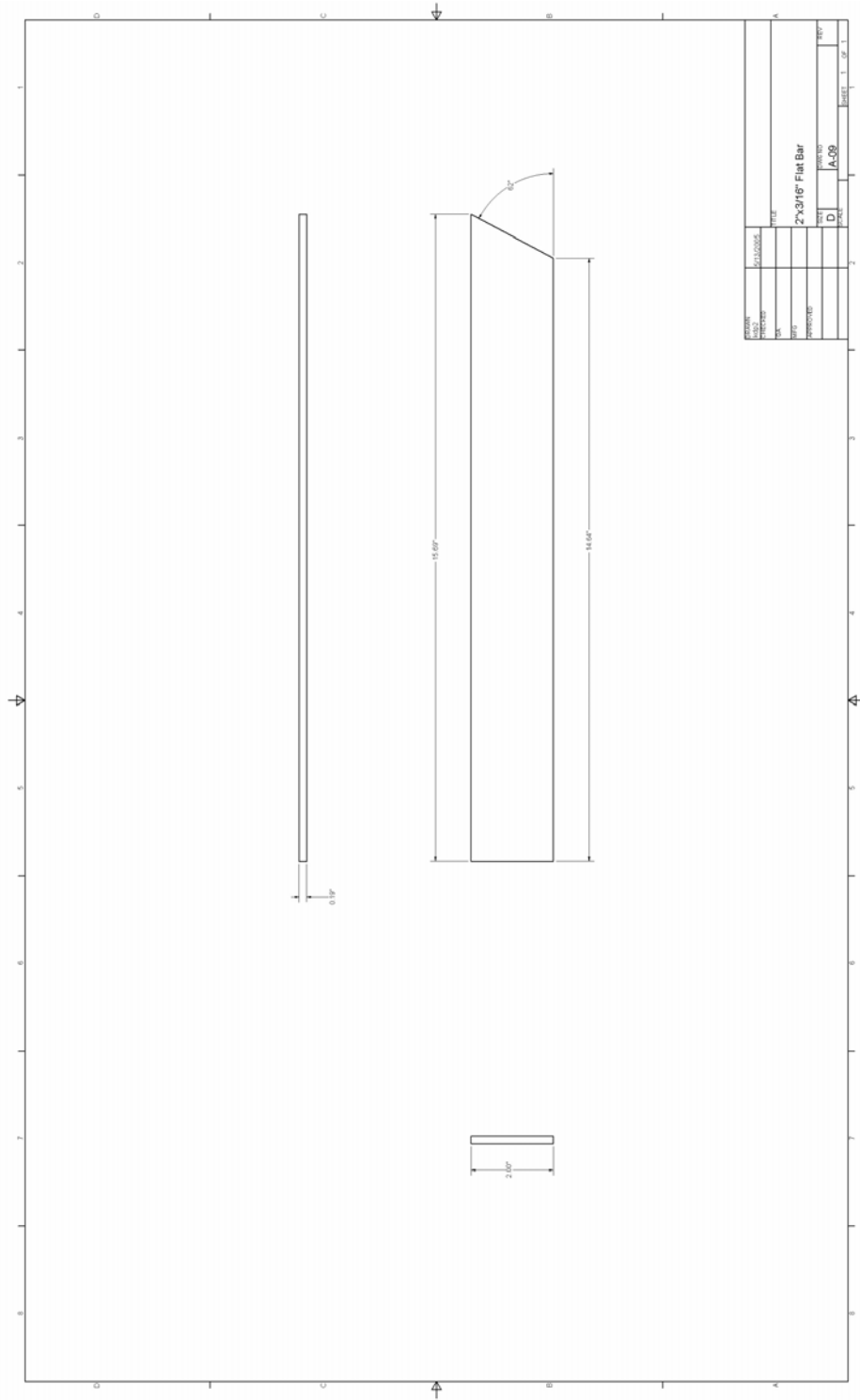

DESIGNER	DATE	SCALE	PROJECT
DR	10/10/10	1:1	2x3 1/2" Flat Bar
CHECKED			
APPROVED			
DATE	REV	BY	APP
10/10/10	1	DR	DR
DRAWN BY			10/10/10
CHECKED BY			10/10/10
APPROVED BY			10/10/10
DATE			10/10/10
SCALE			1:1
PROJECT			2x3 1/2"

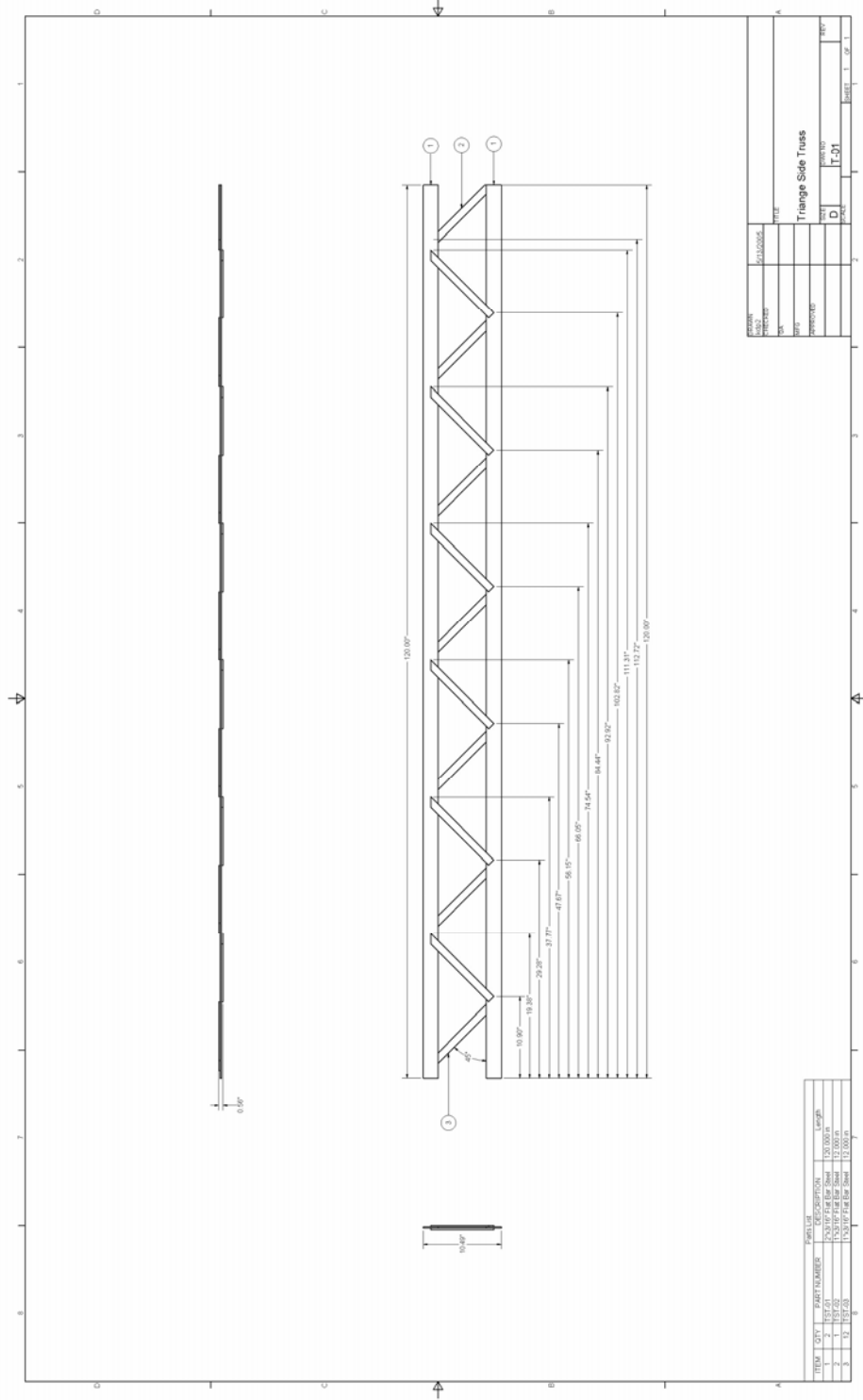

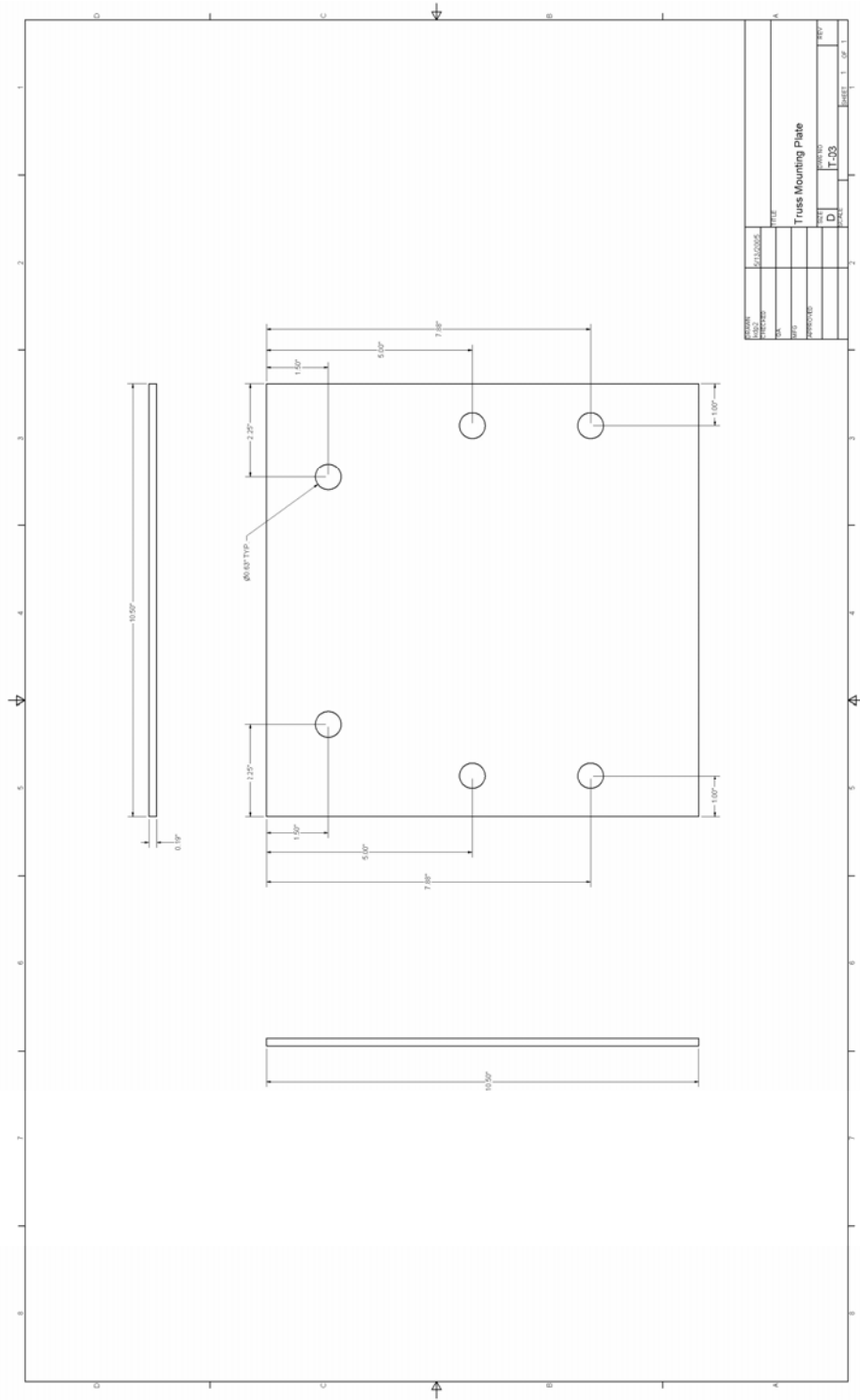

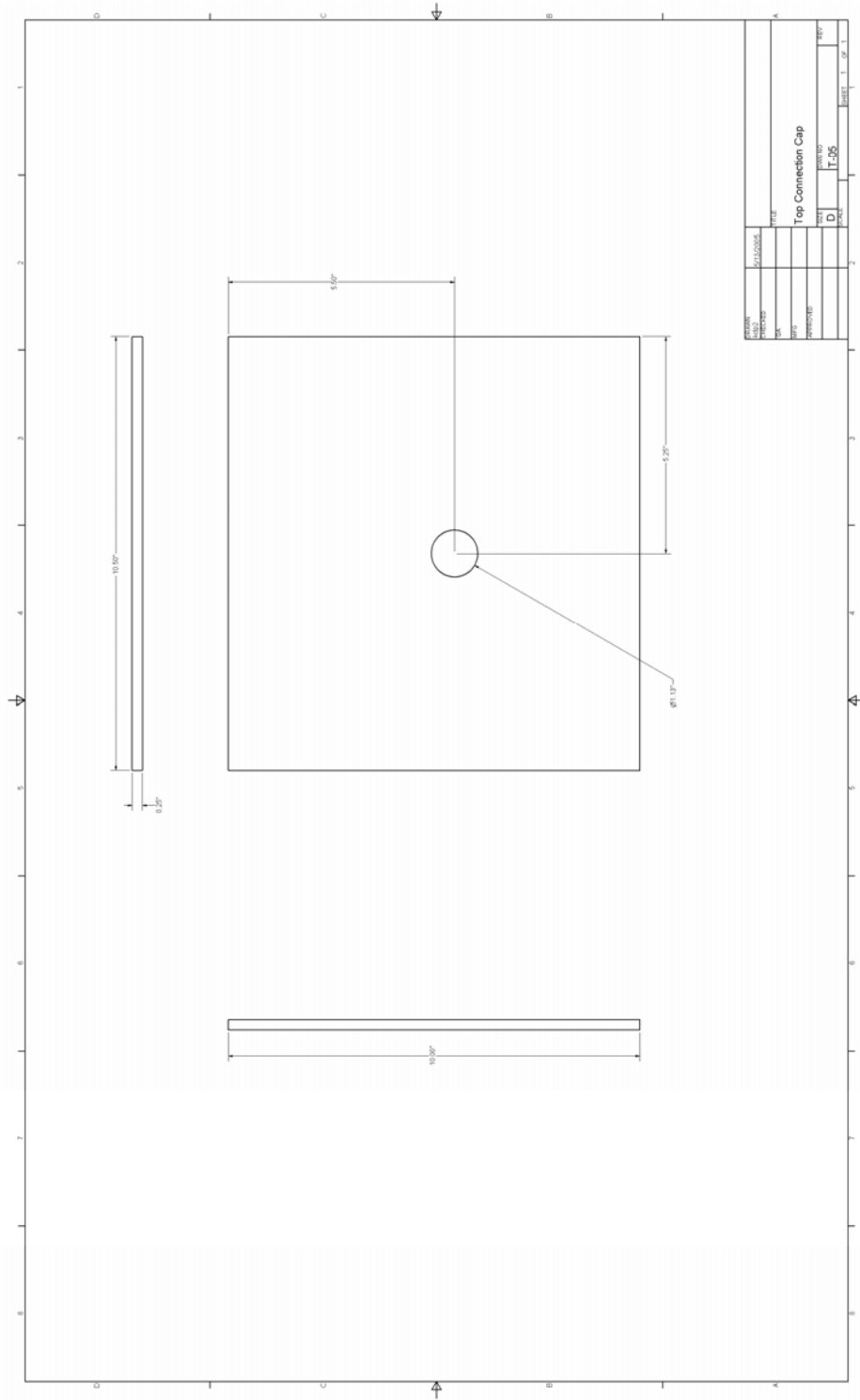

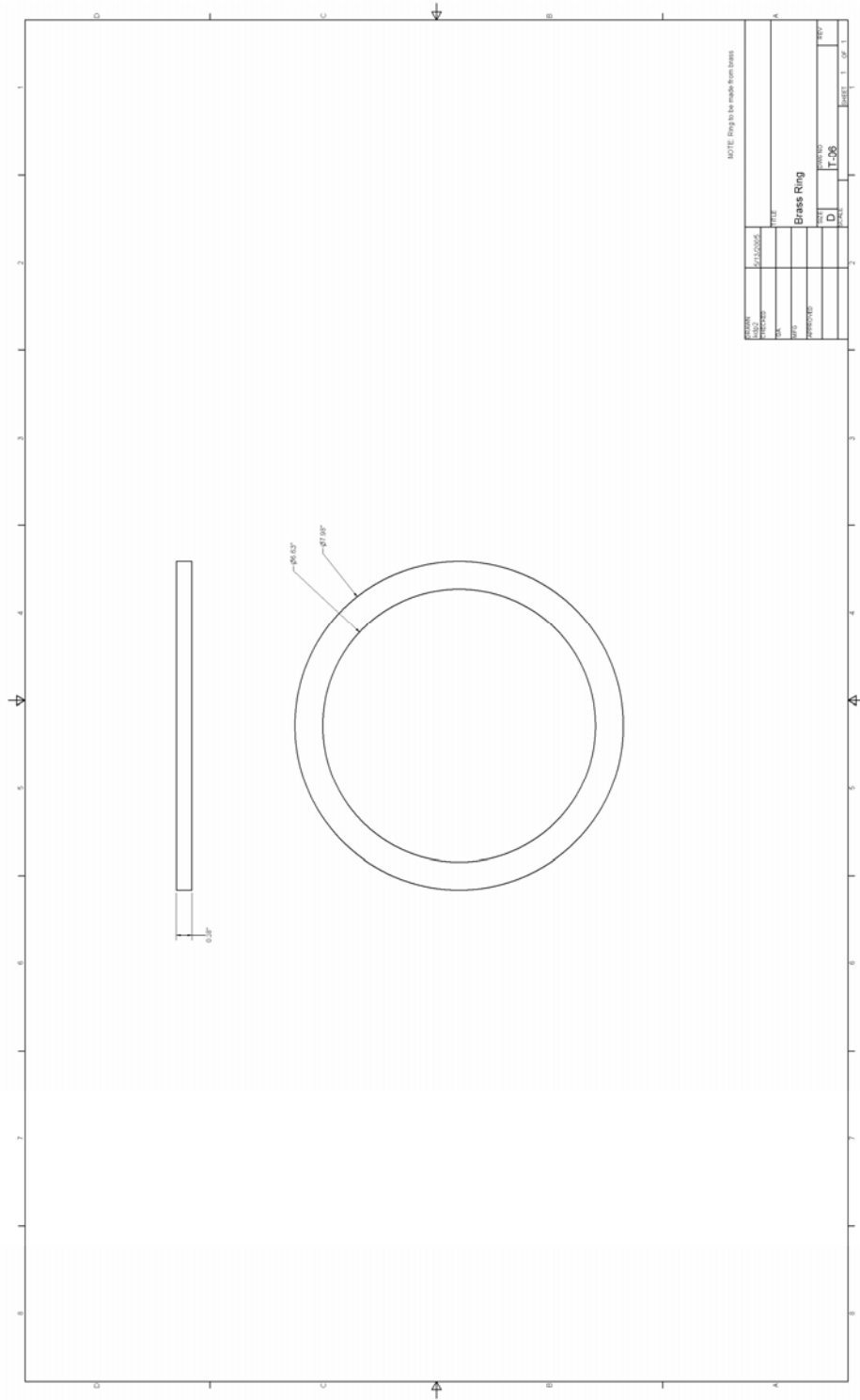

NOTE: Ring to be made from brass.

DESIGNER	DATE	TITLE
DRWING	1-96	Brass Ring
CHKD		
APP'D		
APPROVED		
DATE	1-96	BY
D.C.		J.S.P.
CHECKED	1-96	

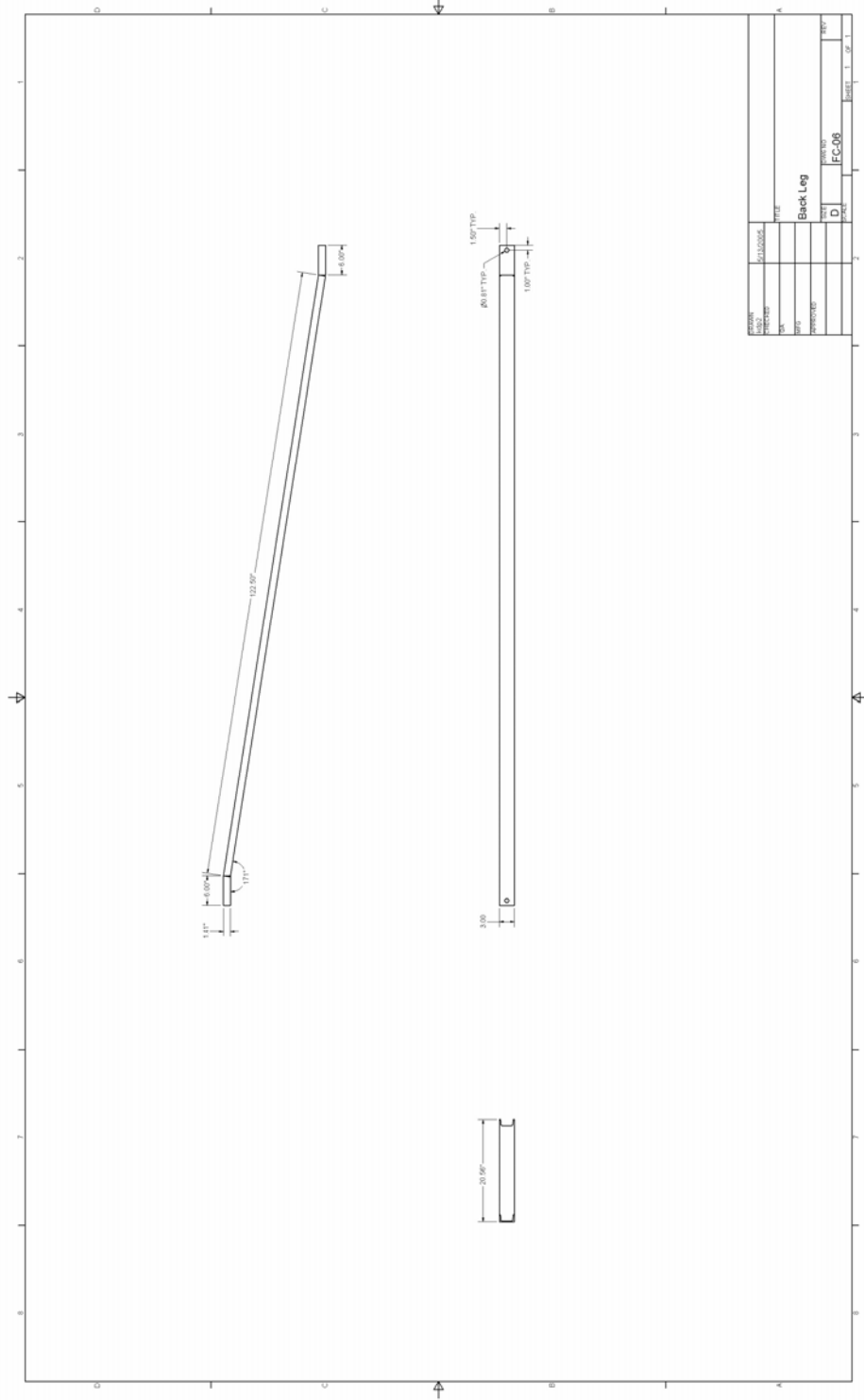

APPENDIX C: PROTOTYPE DESIGN MATHCAD CALCULATIONS

Appendix C.1 --- Anchoring Bolts

Description:

There are eight bolts that hold the crane down on the trailer. Four of these are in the front section of the frame, and four are in the back section of the frame. These bolts must counteract the moment of the loaded crane to keep the crane from ripping off of the trailer and tipping over.

This sheet calculates the size bolts needed and the safety factor of those bolts. The method used for these bolt calculations comes from Juvinall & Marshek, Chapter 10.

Assumptions:

- Maximum load of 500 lbf at full 10 ft extension
- Worst case will be for the bolts in section of frame under the A-frame (the front) when the crane is loaded to the side.

Results:

Using 3/8-in diameter bolts gives us a safety factor of nearly 3.

We will use SAE grade 1 bolts:

Proofstrength := 33000psi (from Table 10.4, Juvinall & Marshek)

Assume max load of 500 lb at maximum extension

Load := 500lbf Arm := 10-ft
 Truss := 100lbf Moment := Load·Arm + Truss · $\frac{Arm}{2}$

Worst case Side loading, assuming two bolts counteract the entire moment. The 3 ft length is based on the width of the base frame

Boltlocate := 3-ft

$$Boltload := \frac{\frac{Moment}{Boltlocate}}{2}$$

Boltload = 916.667lbf This is the total that each of the two bolts carries.

Tensile stress area

$$A_t := \frac{\text{Boltload}}{\text{Proofstrength}}$$

$$A_t = 0.028\text{in}^2$$

A standard bolt with a 3/8-in diameter has a tensile stress area of 0.0775-in².

Safety Factor on bolts, worst case load:

$$\text{SF} := \frac{0.0775\text{in}^2}{A_t} \quad \boxed{\text{SF} = 2.79}$$

We have a safety factor of nearly 3 with these bolts, and this loading situation is somewhat unrealistically modeled; in real conditions, the load could not really go to just two of the bolts.

Appendix C.2 --- Pin Joint Pin Stresses

Description:

The pins in the pin joints must be able to withstand the shear load and the compressive load from the reaction forces at the feet of the crane, which are highest under a side loading condition.

This sheet calculates stress in the pins and fatigue stress limits in the pins. The fatigue stress is calculated using a method from Chapter 8 of Juvinal & Marshek.

Assumptions:

-Maximum load of 500-lbf at full 10-ft extension off the side.

Results:

The shear and compressive surface stress on the pins are relatively small, and the combination of these stresses give a max compressive stress of 5128 psi and a max shear stress of 3908 psi. The fatigue stress limit for 10⁶ cycle strength is about 19000 psi, so fatigue should not be an issue.

Pin Shear Stress Calculations

$$D := 0.75 \text{ in} \quad F_{D1} := 1640 \text{ lbf} \quad (\text{This is the highest reaction force in the crane})$$

$$A := \pi \cdot \left(\frac{D}{2}\right)^2 \quad A = 0.442 \text{ in}^2$$

$$\tau := \frac{F_{D1}}{A} \quad \boxed{\tau = 3712.20 \text{ lpsi}}$$

Local Surface Compressive Stress

$$t := .356 \text{ in} + 0.5 \text{ in} \quad (\text{thickness of metal beam})$$

$$A_{\text{contact}} := \pi \cdot D \cdot \frac{1}{3} \cdot t \quad A_{\text{contact}} = 0.672 \text{ in}^2$$

$$\dots \quad F_{D1} \quad \underline{\hspace{2cm}}$$

Fatigue Limit, 10⁶ cycle strength

see page 316, Juvinall & Marshek

$$S_u := 60000 \text{psi}$$

$$S_{nprime} := 0.5 \cdot S_u$$

$$C_L := 1$$

$$C_G := 0.8$$

$$C_S := 0.8$$

$$S_n := S_{nprime} \cdot C_L \cdot C_G \cdot C_S$$

$$S_n = 19200 \text{psi}$$

Appendix C.3 --- Reaction Forces, front extension

Description:

The reaction forces at the front and back legs are necessary for calculating stresses in the pins at each joint, and also for calculating bending, compressive, and tensile stresses in the legs of the crane.

This sheet calculates estimates of the reaction forces at each foot of the crane for a front loading condition using simple static analysis techniques. It then uses this to calculate bending stress in the front legs and the axial stress in the rear legs.

Assumptions:

-Maximum load of 500-lbf at full 10-ft extension off the front.

Results:

With no flat bar cross bracing, the front legs have a safety factor of only 1 with respect to the ASD standard for bending stress. The best case scenario in which the flatbar cross bracing adds to the moment of inertia gives a safety factor of 1.67. In reality, the safety factor is likely somewhere in between these two values.

The axial stress on the back legs is 404 psi, which is very little.

Dimensions and Loads

$h := 104 \text{ in}$ (length AD) $d := 89 \text{ in}$ (length CD)

$h_t := 120 \text{ in}$ (total height, length ED)

$l_{\text{arm}} := 10 \text{ ft}$ Load := 500 lbf truss := 80 lbf

$\theta := \text{atan}\left(\frac{d}{h}\right)$ $\theta = 40.556 \text{ deg}$

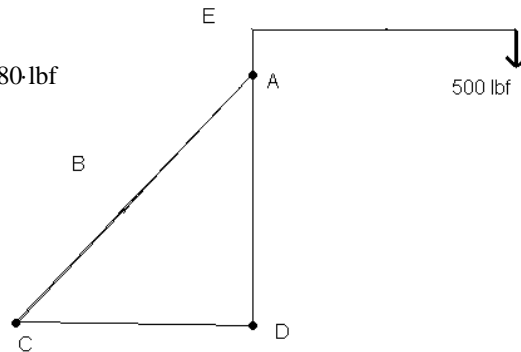

$M := \text{Load} \cdot l_{\text{arm}} + \text{truss} \cdot \frac{l_{\text{arm}}}{2}$ $M = 5400 \text{ lbf} \cdot \text{ft}$

$$F_A := \frac{M}{h \cdot \sin(\theta) \cdot 2} \quad (\text{Moments about } D) \quad F_A = 479.151 \text{ lbf} \quad (\text{T})$$

$$F_{Dx} := \frac{M}{h \cdot 2} \quad (\text{Moments about } A) \quad F_{Dx} = 311.538 \text{ lbf}$$

$$F_{Dy} := \frac{\text{Load} + \text{truss} + 2 \cdot F_A \cdot \cos(\theta)}{2} \quad (\text{Sum of y-forces}) \quad F_{Dy} = 654.045 \text{ lbf} \quad (\text{C})$$

$$F_D := \sqrt{F_{Dx}^2 + F_{Dy}^2} \quad (\text{Gives magnitude of force on pins}) \quad F_D = 724.452 \text{ lbf}$$

Bending Stress in A-Frame legs (worst case without the cross bracing):

$$I_{\text{channel}} := 2.07 \cdot \text{in}^4$$

$$M := \text{Load} \cdot l_{\text{arm}} + \text{truss} \cdot \frac{l_{\text{arm}}}{2}$$

(Since the bottoms of the front legs are just pinned, the force from the back legs does nothing to counteract the bending moment)

$$M = 5400 \text{ ft} \cdot \text{lbf}$$

$$c := 1.5 \text{ in} \quad (\text{half the width of the channel})$$

$$\sigma_{\text{bendfront}} := \frac{M \cdot c}{I_{\text{channel}} \cdot 2} \quad (\text{Moment of Inertia of channel is multiplied by 2 because there are 2 legs})$$

$$\sigma_{\text{bendfront}} = 23478.26 \text{ lpsi}$$

$$\text{target} := 36000 \text{ psi} \cdot \frac{2}{3} \quad (\text{Allowable Stress Design bending standard})$$

$$\text{SF} := \frac{\text{target}}{\sigma_{\text{bendfront}}}$$

$$\boxed{\text{SF} = 1.022}$$

This is not good.

Bending Stress in A-Frame legs (best case with cross bracing adding to the moment of Inertia):

$$I_{\text{flatbar}} := \frac{\left[1.41 \cdot \text{in} \cdot (3.5 \cdot \text{in})^3\right] - \left[1.41 \cdot \text{in} \cdot (3 \cdot \text{in})^3\right]}{12} \quad I_{\text{flatbar}} = 1.865 \text{in}^4$$

$$I_{\text{bestcase}} := I_{\text{channel}} + I_{\text{flatbar}} \quad I_{\text{bestcase}} = 3.935 \text{in}^4$$

$$c_{\text{bestcase}} := 1.75 \text{in}$$

$$\sigma_{\text{bendbest}} := \frac{M \cdot c_{\text{bestcase}}}{I_{\text{bestcase}} \cdot 2} \quad \sigma_{\text{bendbest}} = 14408.004 \text{psi}$$

$$SF_{\text{best}} := \frac{\text{target}}{\sigma_{\text{bendbest}}} \quad \boxed{SF_{\text{best}} = 1.666}$$

Axial Stress in back legs:

$$\theta_{\text{backlegs}} := 11.5 \text{deg} \quad (\text{angle each back leg points out at})$$

$$F_{\text{axial}} := \frac{F_A}{\cos(\theta_{\text{backlegs}})} \quad F_{\text{axial}} = 488.966 \text{bf}$$

$$A_{\text{backlegs}} := 1.21 \cdot \text{in}^2 \quad (\text{cross section of back leg channel})$$

$$\sigma_{\text{axial}} := \frac{F_{\text{axial}}}{A_{\text{backlegs}}} \quad \sigma_{\text{axial}} = 404.104 \text{psi} \quad (\text{tension})$$

$$F_D := \sqrt{F_{Dx}^2 + F_{Dy}^2} \quad (\text{Gives magnitude of force on pins}) \quad F_D = 320.217\text{ lbf}$$

Bending Stress in A-Frame legs (worst case without the cross bracing):

$$I_{\text{channel}} := 2.07 \cdot \text{in}^4$$

$$M := \text{Load} \cdot l_{\text{arm}} + \text{truss} \cdot \frac{l_{\text{arm}}}{2}$$

(Since the bottoms of the front legs are just pinned, the force from the back legs does nothing to counteract the bending moment)

$$M = 5400\text{ ft} \cdot \text{lbf}$$

$$c := 1.5 \cdot \text{in} \quad (\text{half the width of the channel})$$

$$\sigma_{\text{bendfront}} := \frac{M \cdot c}{I_{\text{channel}} \cdot 2} \quad (\text{Moment of Inertia of channel is multiplied by 2 because there are 2 legs})$$

$$\sigma_{\text{bendfront}} = 2.348 \times 10^4 \text{ psi}$$

$$\text{target} := 36000 \text{ psi} \cdot \frac{2}{3} \quad (\text{Allowable Stress Design bending standard})$$

$$\text{SF} := \frac{\text{target}}{\sigma_{\text{bendfront}}}$$

$$\boxed{\text{SF} = 1.022}$$

This is not good.

Bending Stress in A-Frame legs (best case with cross bracing adding to the moment of Inertia):

$$I_{\text{flatbar}} := \frac{\left[1.41 \cdot \text{in} \cdot (3.5 \cdot \text{in})^3 \right] - \left[1.41 \cdot \text{in} \cdot (3 \cdot \text{in})^3 \right]}{12}$$

$$I_{\text{flatbar}} = 1.865 \text{ in}^4$$

$$I_{\text{bestcase}} := I_{\text{channel}} + I_{\text{flatbar}}$$

$$I_{\text{bestcase}} = 3.935 \text{ in}^4$$

$$c_{\text{bestcase}} := 1.75 \cdot \text{in}$$

$$\sigma_{\text{bendbest}} := \frac{M \cdot c_{\text{bestcase}}}{I_{\text{bestcase}} \cdot 2}$$

$$\sigma_{\text{bendbest}} = 1.441 \times 10^4 \text{ psi}$$

$$\text{SF}_{\text{best}} := \frac{\text{target}}{\sigma_{\text{bendbest}}}$$

$$\boxed{\text{SF}_{\text{best}} = 1.666}$$

Axial Stress in back legs:

$$\theta_{\text{backlegs}} := 11.5 \text{ deg} \quad (\text{angle each back leg points out at})$$

$$F_{\text{axial}} := \frac{F_A}{\cos(\theta_{\text{backlegs}})} \quad F_{\text{axial}} = 488.966 \text{ lbf}$$

$$A_{\text{backlegs}} := 1.21 \cdot \text{in}^2 \quad (\text{cross section of back leg channel})$$

$$\sigma_{\text{axial}} := \frac{F_{\text{axial}}}{A_{\text{backlegs}}} \quad \sigma_{\text{axial}} = 404.104 \text{ psi} \quad (\text{compression})$$

Max buckling load that back legs can take:

$$I_{\text{backleg}} := .197 \cdot \text{in}^4$$

$$L_{\text{backlegs}} := 120 \cdot \text{in} \quad E := 29 \cdot 10^6 \cdot \text{psi}$$

$$P_{\text{cr}} := \frac{\pi^2 \cdot E \cdot I_{\text{backleg}}}{L_{\text{backlegs}}^2} \quad P_{\text{cr}} = 3.916 \times 10^3 \text{ lbf}$$

$$SF_{\text{buckleback}} := \frac{P_{\text{cr}}}{F_{\text{axial}}} \quad \boxed{SF_{\text{buckleback}} = 8.008}$$

Appendix C.5 --- Joint Forces, 500 lb load, side extension

Description:
 The reaction forces the two legs of the A-frame are necessary for calculating stresses in the pins at each joint, and also for calculating bending, compressive, and tensile stresses in the legs.

This sheet calculates estimates of the reaction forces at each front foot of the crane for a side loading condition using simple static analysis techniques. It then uses this to calculate bending stress in the front legs

Assumptions:
 -Maximum load of 500-lbf at full 10-ft extension off the side.

Results:
 With no flat bar cross bracing, the bending stress in the front legs is well beyond the allowed limit by ASD bending standards. This combined with the compressive load on one of the legs means that our legs need some substantial cross bracing. The analysis for the legs with added bracing was done using Algor.

Dimensions and Loads

$h_t := 120 \text{ in}$ (total height, length ED)

$l_{\text{arm}} := 10 \text{ ft}$ Load := 500 lbf

$w := 48 \text{ in}$ Top := 16 in

truss := 80 lbf

$\text{Leg} := \sqrt{\left(\frac{w}{2}\right)^2 + (h_t - \text{Top})^2}$

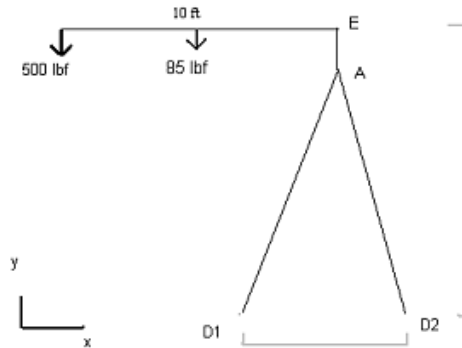

Guess Values

$F_{D1x} := 1 \cdot \text{lbf}$ $F_{D1y} := 1 \cdot \text{lbf}$ $F_{D1} := 1 \cdot \text{lbf}$

$F_{D2x} := 1 \cdot \text{lbf}$ $F_{D2y} := 1 \cdot \text{lbf}$ $F_{D2} := 1 \cdot \text{lbf}$

Given

$F_{D1y} + F_{D2y} = \text{Load} + \text{truss}$ (y forces)

$F_{D1x} = -F_{D2x}$ (x forces)

$0 = \left(\text{Load} \cdot l_{\text{arm}} + \text{truss} \cdot \frac{l_{\text{arm}}}{2} \right) - F_{D1y} \cdot \frac{w}{2} + F_{D1x} \cdot h_t + F_{D2x} \cdot h_t + F_{D2y} \cdot \frac{w}{2}$ (Moments about E)

$$0 = \left(\text{Load} \cdot l_{\text{arm}} + \text{truss} \cdot \frac{l_{\text{arm}}}{2} \right) - F_{D1y} \cdot w + (\text{Load} + \text{truss}) \cdot \frac{w}{2} \quad (\text{Moments about D2})$$

$$F_{D1} = \sqrt{F_{D1x}^2 + F_{D1y}^2} \quad (\text{Magnitude of } F_{D1})$$

$$F_{D2} = \sqrt{F_{D2x}^2 + F_{D2y}^2} \quad (\text{Magnitude of } F_{D2})$$

F_{D1x}	:= Find($F_{D1x}, F_{D1y}, F_{D2x}, F_{D2y}, F_{D1}, F_{D2}$)	$F_{D1x} = -28.912\text{bf}$	$F_{D1y} = 1640\text{bf}$
F_{D1y}			
F_{D2x}		$F_{D2x} = 28.912\text{bf}$	$F_{D2y} = -1060\text{bf}$
F_{D2y}			
F_{D1}			
F_{D2}			

Buckling load on leg:

$$F_{D1} = 1640.255\text{bf} \quad F_{D2} = 1060.394\text{bf}$$

$$\theta := \text{asin}\left(\frac{\frac{w}{2}}{h_t - \text{Top}}\right) \quad \theta = 13.342\text{deg}$$

$$F_{D1} = 1640.255\text{bf} \quad F_{D1\text{comp}} := F_{D1} \cdot \cos(\theta) \quad F_{D1\text{comp}} = 1595.982\text{bf}$$

$$L_e := \text{Leg} \quad L_e = 106.733\text{in} \quad E := 3000000\text{psi} \quad I := .305\text{in}^4$$

$$P_{\text{cr}} := \frac{\pi^2 \cdot E \cdot I}{L_e^2} \quad P_{\text{cr}} = 7927.219\text{bf} \quad SF_{\text{buckle}} := \frac{P_{\text{cr}}}{F_{D1\text{comp}}} \quad SF_{\text{buckle}} = 4.967$$

Bending load on one leg:

$$F_{D1\text{bend}} := F_{D1} \cdot \sin(\theta) \quad F_{D1\text{bend}} = 378.52\text{bf}$$

$$M := F_{D1\text{bend}} \cdot \text{Leg} \quad C := .455\text{in}$$

$$\sigma_{\text{bend}} := \frac{M \cdot C}{I} \quad \sigma_{\text{bend}} = 60269.94\text{psi}$$

Way too high; this is why we need cross bracing.

Appendix C.6 --- Top channel and pipe bending

Description:

There must not be any bending at the top of the A-Frame where the truss connects. This top part consists of an outer pipe (called the middle pipe in the report) surrounding two pieces of channel surrounding an inner pipe. Below this top part is a small section of just the channel and the inner pipe that also must be able to resist bending.

This sheet calculates the bending stress in these three parts assuming that they are all fixed together. We are using the Allowable Stress Design bending limit of $0.66S_y$, which for our steel is 24 ksi.

Assumptions:

-Maximum load of 500-lbf at full 10-ft extension
 -Orientation is such that the moment of inertia for the channel is minimized to model worst case scenario

Results:

With all three parts welded together, our top has a bending stress safety factor of just under 2, and the section below this has a safety factor of just over 1 (which is a weak point in our design). This is addressed in our theoretical design appendix.

Moments of inertia for each component of this assembly:

MIDDLE PIPE:

$$D := 4.5 \text{ in} \quad d := 4.075 \text{ in}$$

$$I_{\text{mid}} := \frac{\pi \cdot \left[\left(\frac{D}{2} \right)^4 - \left(\frac{d}{2} \right)^4 \right]}{4} \quad I_{\text{mid}} = 6.593 \text{ in}^4$$

CHANNEL:

$$b_o := 3.05 \text{ in} \quad h_o := 3.065 \text{ in}$$

$$b_i := 2.47 \text{ in} \quad h_i := 2.5 \text{ in}$$

$$I_{\text{channel}} := \frac{b_o \cdot h_o^3}{12} - \frac{b_i \cdot h_i^3}{12} \quad I_{\text{channel}} = 4.102 \text{ in}^4$$

INNER PIPE:

$$D_1 := 2.375 \text{ in} \quad d_1 := 2.067 \text{ in}$$

$$I_{\text{inner}} := \frac{\pi \cdot \left[\left(\frac{D_1}{2} \right)^4 - \left(\frac{d_1}{2} \right)^4 \right]}{4} \quad I_{\text{inner}} = 0.666 \text{ in}^4$$

TOTAL moment of inertia:

$$I := I_{\text{mid}} + I_{\text{channel}} + I_{\text{inner}} \quad \boxed{I = 11.361 \text{ in}^4}$$

Moment and force:

$$\text{Load} := 500 \text{ lbf} \quad \text{Truss} := 120 \text{ lbf}$$

$$\text{Arm} := 10 \text{ ft}$$

$$M := \text{Load} \cdot \text{Arm} + \text{Truss} \cdot \frac{\text{Arm}}{2} \quad M = 5600 \text{ ft} \cdot \text{lbf}$$

Strength of steel:

$$\text{strength}_{\text{tensile}} := 36000 \text{ psi}$$

$$\text{target} := \frac{2}{3} \cdot \text{strength}_{\text{tensile}}$$

Bending Stress of all three components:

$$\sigma_{\text{bend}} := \frac{M \cdot \frac{D}{2}}{I} \quad \sigma_{\text{bend}} = 13308.564 \text{ psi}$$

$$\text{SF} := \frac{\text{target}}{\sigma_{\text{bend}}} \quad \boxed{\text{SF} = 1.803}$$

Bending stress in bottom (just 2 components)

$$I_2 := I_{\text{channel}} + I_{\text{inner}} \quad \sigma_{\text{bend2}} := \frac{M \cdot \frac{b_o}{2}}{I_2} \quad \sigma_{\text{bend2}} = 21493.747 \text{ psi}$$

$$\text{SF}_2 := \frac{\text{target}}{\sigma_{\text{bend2}}} \quad \boxed{\text{SF}_2 = 1.117}$$

Appendix C.7 --- Track/Truss Bolts

Description:

There are fourteen bolts that hold the rail track on to the bottom of the truss. They are spaced at alternating intervals of approximately 13-in and 5-in. These bolts must carry the load of the winch and the packed tire as the winch is moved in and out along the track.

This sheet helps determine if the bolts we are using for this are strong enough. The method used for these bolt calculations comes from Juvinal & Marshek, Chapter 10.

Assumptions:

- Maximum load of 500-lbf
- Worst case is entire 500-lbf load held by one bolt.

Results:

Using 3/8-in diameter bolts gives us a safety factor of over 3 for an unrealistically bad loading condition. In practice, the safety factor is even higher than this.

Worst case is modeled to be all the weight under one bolt.

$$\text{Load} := 500\text{ lbf}$$

We are using SAE grade 1 bolts:

$$\text{Proofstrength} := 33000\text{ psi} \quad (\text{from Table 10.4, Juvinal \& Marshek})$$

We desire a safety factor of 3:

$$\text{SF} := 3$$

Tensile stress area:

$$A_t := \frac{\text{Load} \cdot \text{SF}}{\text{Proofstrength}}$$

$$A_t = 0.045\text{ in}^2 \quad \text{This is the tensile stress area we need for a safety factor of 3.}$$

A standard bolt with a 0.3125-in diameter has a tensile stress area of 0.0524-in².

Our bolts are 0.375-in diameter bolts, which is larger than the necessary.

Appendix C.8 --- Roll Track Bending Stress

Description:

The load of the tire is held by two carts that roll in the track on the bottom of the truss. The bottom of the track curls around and acts like a cantilever beam to hold the carts.

This sheet calculates the bending stress in the bottom of the roll track.

Assumptions:

- Max load of 500 lbf
- Treat track like a cantilever
- Model load from the cart wheels as being concentrated 3/10" from the side of the track.

Results:

The bending stress in the track is about 10000 psi, giving a factor of safety of over 3.

$$b := 12 \cdot \text{in} \quad (\text{distance along the track covered by two carts})$$

$$h := 0.0625 \cdot \text{in} \quad (\text{thickness of track metal})$$

$$I := \frac{b \cdot h^3}{12} \quad I = 2.441 \times 10^{-4} \cdot \text{in}^4$$

$$l := .3 \cdot \text{in} \quad (\text{approximate distance from bend that load is concentrated on})$$

$$\text{Load} := 250 \cdot \text{lbf} \quad (\text{half of the tire load is on each side of the track})$$

$$M := \text{Load} \cdot l \quad M = 6.25 \cdot \text{lbf} \cdot \text{ft}$$

$$c := \frac{h}{2} \quad c = 0.031 \cdot \text{in}$$

$$\sigma := \frac{M \cdot c}{I} \quad \boxed{\sigma = 9600 \text{psi}}$$

$$S_y := 36000 \text{psi}$$

$$\text{SF} := \frac{S_y}{\sigma} \quad \boxed{\text{SF} = 3.75}$$

Appendix C.9 --- Welds Truss Connection

Description:

The truss is welded to a plate that is bolted to the top of the crane. These welds are responsible for holding the entire moment load of the truss and packed tire.

This sheet calculates the size of the welds needed in this connection using the gusset and truss geometry we have designed. The method used for these weld calculations comes from Juvinall & Marshek, Chapter 11, section 5.

Assumptions:

- Maximum load of 500 lbf at full 10 ft extension
- Desired safety factor of 3.
- Welds are placed as shown in diagram.

Results:

Welds 1/8" thick will hold with a safety factor of over 3. In reality, the welds on our crane are all larger than this.

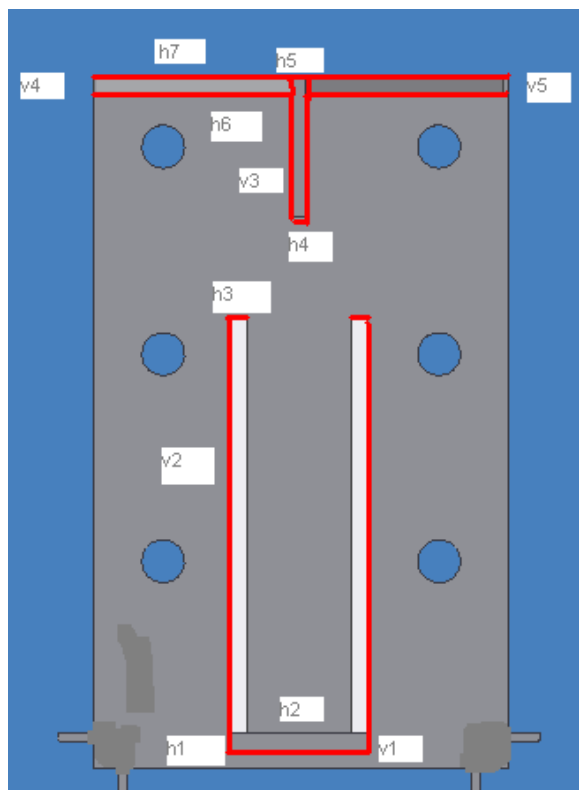

Areas of pieces:

Distances from bottom to center of pieces:

$$R_1 := 2 \cdot \text{in} \cdot .25 \text{ in}$$

$$D_1 := .125 \text{ in}$$

$$R_2 := 6 \cdot \text{in} \cdot .25 \text{ in}$$

$$D_2 := 3.125 \text{ in}$$

$$R_3 := R_2$$

$$D_3 := D_2$$

$$R_4 := 1 \cdot \text{in} \cdot .25 \text{ in}$$

$$D_4 := 8.5 \text{ in}$$

$$R_5 := 2 \cdot \text{in} \cdot .25 \text{ in}$$

$$D_5 := 8.75 \text{ in}$$

$$R_6 := 2 \cdot \text{in} \cdot .25 \text{ in}$$

$$D_6 := 8.75 \text{ in}$$

Center of Gravity line

$$CG := \frac{R_1 \cdot D_1 + R_2 \cdot D_2 + R_3 \cdot D_3 + R_4 \cdot D_4 + R_5 \cdot D_5 + R_6 \cdot D_6}{R_1 + R_2 + R_3 + R_4 + R_5 + R_6}$$

$$CG = 4.276 \text{ in}$$

Weld distance from CG

Weld Length

$$a_1 := CG$$

$$L_{h1} := 2 \cdot \text{in}$$

$$L_{v1} := .25 \text{ in}$$

$$a_2 := a_1 - .25 \text{ in}$$

$$L_{h2} := 1.5 \text{ in}$$

$$L_{v2} := 6 \cdot \text{in}$$

$$a_3 := 6 \cdot \text{in} - CG$$

$$L_{h3} := .5 \cdot \text{in}$$

$$L_{v3} := 1 \cdot \text{in}$$

$$a_4 := 8 \cdot \text{in} - CG$$

$$L_{h4} := .25 \cdot \text{in}$$

$$L_{v4} := .25 \cdot \text{in}$$

$$a_5 := 9 \cdot \text{in} - CG$$

$$L_{h5} := .25 \cdot \text{in}$$

$$L_{v5} := .25 \cdot \text{in}$$

$$a_6 := 8.5 \cdot \text{in} - CG$$

$$L_{h6} := 2 \cdot \text{in}$$

$$a_7 := 8.75 \cdot \text{in} - CG$$

$$L_{h7} := 2 \cdot \text{in}$$

Stress on weld

Load := 500 lbf Truss := 80 lbf Length := 120 in

$$M := \text{Load} \cdot \text{Length} + \text{Truss} \cdot \frac{\text{Length}}{2} \quad M = 6.48 \times 10^4 \text{ lbf} \cdot \text{in}$$

c := 9 in - CG

$$\sigma := \frac{M \cdot c}{I_x} \quad \sigma \rightarrow 1175.0768186525383726 \frac{\text{lbf}}{\text{in} \cdot \text{t}}$$

$y_s := 50750 \text{ psi}$

FS := 3

$$t := \frac{1175 \frac{\text{lbf}}{\text{in}}}{\left(\frac{y_s \cdot .58}{3} \right)} \quad \boxed{t = 0.12 \text{ in}}$$

Appendix C.10 --- Welds Truss Connection (side load)

Description:

The truss is welded to a plate that is bolted to the top of the crane. The welds must hold the side force of the crane being rotated.

This sheet calculates the size of the welds needed in this connection using the gusset and truss geometry we have designed. The method used for these weld calculations comes from Juvinall & Marshek, Chapter 11, section 5.

Assumptions:

- Side force of 300 lbf
- Desired safety factor of 3.
- Weld placement is as shown in the diagram.

Results:

Welds 0.3" thick will hold with a safety factor of over 3. In reality, the welds on our crane are not quite this large. This problem could be mended with the use of more gussets or a wider truss, which we do have in our theoretical truss design. Also, the assumption of a side force of 300 lbf is very unlikely to actually occur.

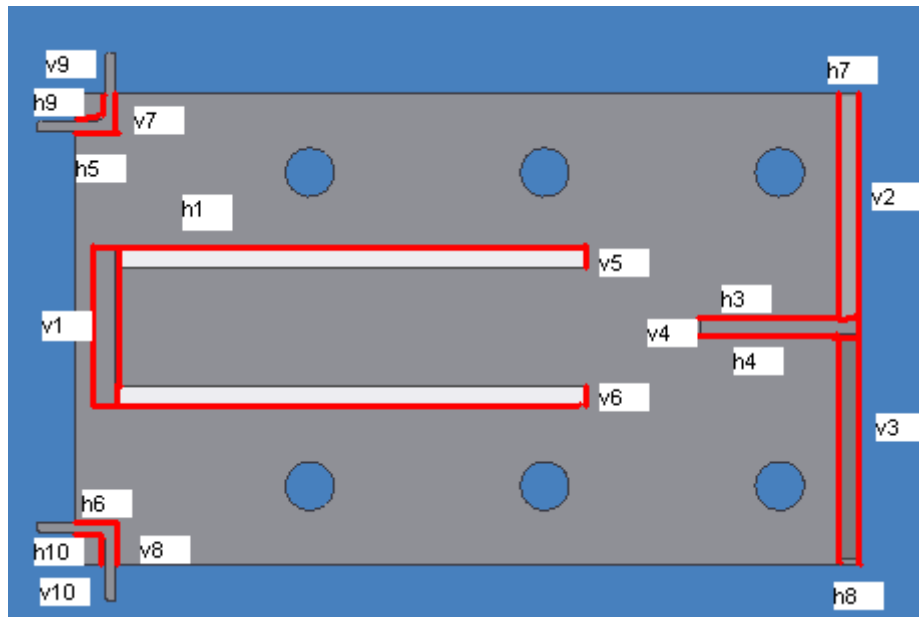

Center of Gravity line

$$CG := 3 \cdot \text{in}$$

Weld distance from CG

Weld Length

$$a_1 := 1 \cdot \text{in}$$

$$L_{h1} := 6.25 \cdot \text{in}$$

$$L_{v1} := 2 \cdot \text{in}$$

$$a_2 := a_1$$

$$L_{h2} := L_{h1}$$

$$L_{v2} := 2.906 \cdot \text{in}$$

$$a_3 := .09375 \cdot \text{in}$$

$$L_{h3} := 2 \cdot \text{in}$$

$$L_{v3} := 2.906 \cdot \text{in}$$

$$a_4 := a_3$$

$$L_{h4} := L_{h3}$$

$$L_{v4} := .25 \cdot \text{in}$$

$$a_5 := 2.5 \cdot \text{in}$$

$$L_{h5} := .5 \cdot \text{in}$$

$$L_{v5} := .25 \cdot \text{in}$$

$$a_6 := a_5$$

$$L_{h6} := L_{h5}$$

$$L_{v6} := .25 \cdot \text{in}$$

$$a_7 := 3 \cdot \text{in}$$

$$L_{h7} := .25 \cdot \text{in}$$

$$L_{v7} := .5 \cdot \text{in}$$

$$a_8 := a_7$$

$$L_{h8} := L_{h7}$$

$$L_{v8} := L_{v7}$$

$$a_9 := a_5 + .125 \cdot \text{in}$$

$$L_{h9} := .375 \cdot \text{in}$$

$$L_{v9} := .375 \cdot \text{in}$$

$$a_{10} := a_9$$

$$L_{h10} := L_{h9}$$

$$L_{v10} := .375 \cdot \text{in}$$

Horizontal welds

$$I_{h1} := I_{h1} \cdot t \cdot a_1^2 \quad I_{h1} \rightarrow 6.25 \text{in}^3 \cdot t$$

$$I_{h2} := I_{h2} \cdot t \cdot a_2^2 \quad I_{h2} \rightarrow 6.25 \text{in}^3 \cdot t$$

$$I_{h3} := I_{h3} \cdot t \cdot a_3^2 \quad I_{h3} \rightarrow 1.757812500^{-2} \cdot \text{in}^3 \cdot t$$

$$I_{h4} := I_{h4} \cdot t \cdot a_4^2 \quad I_{h4} \rightarrow 1.757812500^{-2} \cdot \text{in}^3 \cdot t$$

$$I_{h5} := I_{h5} \cdot t \cdot a_5^2 \quad I_{h5} \rightarrow 3.125 \text{in}^3 \cdot t$$

$$I_{h6} := I_{h6} \cdot t \cdot a_6^2 \quad I_{h6} \rightarrow 3.125 \text{in}^3 \cdot t$$

$$I_{h7} := I_{h7} \cdot t \cdot a_7^2 \quad I_{h7} \rightarrow 2.25 \text{in}^3 \cdot t$$

$$I_{h8} := I_{h8} \cdot t \cdot a_8^2 \quad I_{h8} \rightarrow 2.25 \text{in}^3 \cdot t$$

$$I_{h9} := I_{h9} \cdot t \cdot a_9^2 \quad I_{h9} \rightarrow 2.583984375 \text{in}^3 \cdot t$$

$$I_{h10} := I_{h10} \cdot t \cdot a_{10}^2 \quad I_{h10} \rightarrow 2.583984375 \text{in}^3 \cdot t$$

$$I_x := 2 \cdot I_{v1} + 2 \cdot I_{v2} + 2 \cdot I_{v3} + 2 \cdot I_{v4} + I_{v5} + I_{v6} + I_{v7} + I_{v8} + I_{v9} + I_{v10} + I_{h1} + I_{h2} + I_{h3} + I_{h4} + I_{h5} + I_{h6} + I_{h7} + I_{h8} + I_{h9} + I_{h10}$$

$$I_x \rightarrow 38.001520201166666667 \text{in}^3 \cdot t$$

Stress on weld

Load := 300lbf Length := 120in

M := Load·Length M = 3.6 × 10⁴ lbf·in

c := 6in – CG

$$\sigma := \frac{M \cdot c}{I_x} \quad \sigma \rightarrow 2841.9915684500522474 \frac{\text{lbf}}{\text{in}^2}$$

y_s := 50750psi

FS := 3

$$t := \frac{2850 \frac{\text{lbf}}{\text{in}}}{\left(\frac{y_s \cdot .58}{3} \right)} \quad \boxed{t = 0.29 \text{in}}$$

Appendix C.11 --- Welds Big Pipe & Truss

Description:

The truss connection plate that bolts the truss to the top swivel connection is welded to the outer pipe of the swivel connection using a piece of 3-inch channel. The welds on this piece of channel must hold the moment from the weight of the truss and the load of a packed tire.

This sheet calculates the size of the welds needed in this connection using the geometry of the welds around the channel. The method used for these weld calculations comes from Jvinall & Marshek, Chapter 11, section 5.

Assumptions:

- Maximum load of 500 lbf at full 10 ft extension
- Desired safety factor of 3.
- Weld consists of two vertical lines 9 inches long

Results:

Welds 1/6" thick will hold with a safety factor of over 3. In reality, the welds on our crane are all larger than this.

Areas of pieces

Distances from bottom to center of pieces

$$R_1 := 9\text{-in} \cdot 3\text{-in}$$

$$D_1 := 4.5\text{-in}$$

Center of Gravity line

$$CG := 4.5\text{-in}$$

$$CG = 4.5\text{in}$$

Weld distance from CG

Weld Length

$$a_1 := CG$$

$$L_{h1} := 3\text{-in}$$

$$L_{v1} := 9\text{-in}$$

Horizontal I's

$$I_{h1} := L_{h1} \cdot t \cdot a_1^2$$

$$I_{h1} \rightarrow 60.75\text{in}^3 \cdot t$$

Appendix C.12 --- Welds Big Pipe & Truss (side load)**Description:**

The truss connection plate that bolts the truss to the top swivel connection is welded to the outer pipe of the swivel connection using a piece of 3-inch channel. These welds must hold the sideways force of the crane being rotated.

This sheet calculates the size of the welds needed in this connection using the geometry of the welds around the channel. The method used for these weld calculations comes from Jvinall & Marshek, Chapter 11, section 5.

Assumptions:

- Estimated 300 lbf side force
- Desired safety factor of 3.
- Two parallel 9-inch welds 3-inches apart and one perpendicular weld 3-inches long.

Results:

Welds 0.13" thick will hold with a safety factor of over 3.

Areas of pieces

Distances from bottom to center of pieces

$$R_1 := 9\text{-in} \cdot 3\text{-in}$$

$$D_1 := 1.5\text{-in}$$

Center of Gravity line

$$CG := 1.5\text{-in}$$

$$CG = 1.5\text{in}$$

Weld distance from CG

Weld Length

$$a_1 := CG$$

$$L_{h1} := 9\text{-in}$$

$$L_{v1} := 3\text{-in}$$

Horizontal I's

$$I_{h1} := L_{h1} \cdot t \cdot a_1^2 \quad I_{h1} \rightarrow 20.25 \text{in}^3 \cdot t$$

Vertical Welds

$$I_{v1} := \frac{L_{v1}^3 \cdot t}{12} \quad I_{v1} \rightarrow \frac{9}{4} \cdot \text{in}^3 \cdot t$$

Appendix C.13 --- Truss Connection Bolts

Description:

There are six bolts that hold the truss to the top swivel connection at the top of the A-frame. The bolts connect two plates together using a two-column bolt placement pattern. Under this design, the top two bolts hold the most load and the bottom two bolts hold the least load. The bolts must counteract the large moment caused by the packed tire and the truss.

This sheet helps determine the size and grade needed for these bolts. The method used for these bolt calculations comes from Juvinall & Marshek, Chapter 10.

Assumptions:

-Maximum load of 500-lbf at full 10-ft extension

Results:

We will use six 1/2-in bolts. The top two bolts will be SAE Grade 5, and the bottom and middle bolts will be SAE Grade 1. This gives all bolts a safety factor of over 3.

Assume max load of 500 lb at full 10 ft extension

$$\begin{aligned} \text{Load} &:= 500\text{-lbf} & \text{Arm} &:= 10\text{-ft} \\ \text{Truss} &:= 80\text{-lbf} & \text{Moment} &:= \text{Load} \cdot \text{Arm} + \text{Truss} \cdot \frac{\text{Arm}}{2} \end{aligned}$$

Bolt locations; distance from bottom of plate

$$\begin{aligned} \text{Locate}_{\text{up}} &:= 9\text{-in} & & \text{(top bolts are 9 inches from bottom)} \\ \text{Locate}_{\text{mid}} &:= 6\text{-in} & & \text{(middle bolts are 6 inches from bottom)} \\ \text{Locate}_{\text{low}} &:= 3\text{-in} & & \text{(bottom bolts are 3 inches from bottom)} \end{aligned}$$

Solve system of equations to find the loads in the bolts

Guess Values:

$$\begin{aligned} \text{Load}_{\text{up}} &:= 1\text{-lbf} \\ \text{Load}_{\text{mid}} &:= 1\text{-lbf} \\ \text{Load}_{\text{low}} &:= 1\text{-lbf} \end{aligned}$$

Given

$$2 \cdot \text{Load}_{\text{up}} \cdot \text{Locate}_{\text{up}} + 2 \cdot \text{Load}_{\text{mid}} \cdot \text{Locate}_{\text{mid}} + 2 \cdot \text{Load}_{\text{low}} \cdot \text{Locate}_{\text{low}} = \text{Moment}$$

$$\text{Load}_{\text{up}} = \frac{\text{Locate}_{\text{up}}}{\text{Locate}_{\text{low}}} \cdot \text{Load}_{\text{low}}$$

$$\text{Load}_{\text{up}} = \frac{\text{Locate}_{\text{up}}}{\text{Locate}_{\text{mid}}} \cdot \text{Load}_{\text{mid}}$$

$$\begin{pmatrix} \text{Load}_{\text{up}} \\ \text{Load}_{\text{mid}} \\ \text{Load}_{\text{low}} \end{pmatrix} := \text{Find}(\text{Load}_{\text{up}}, \text{Load}_{\text{mid}}, \text{Load}_{\text{low}})$$

$$\text{Load}_{\text{up}} = 2.314 \times 10^3 \text{ lbf} \quad \text{Load carried by each upper bolt}$$

$$\text{Load}_{\text{mid}} = 1.543 \times 10^3 \text{ lbf} \quad \text{Load carried by each middle bolt}$$

$$\text{Load}_{\text{low}} = 771.429 \text{ lbf} \quad \text{Load carried by each lower bolt}$$

SAE grade 5 bolts (used for the two top bolts since they carry the most load):

$$\text{Proofstrength}_5 := 85000 \text{ psi}$$

Desired Safety Factor of 3:

$$\text{SF} := 3$$

Tensile stress area:

$$A_{t5} := \frac{\text{Load}_{\text{up}} \cdot \text{SF}}{\text{Proofstrength}_5}$$

$$A_{t5} = 0.082 \text{ in}^2$$

A standard bolt with a 1/2-in diameter has a tensile stress area of 0.1419-in², greater than our needed area.

SAE grade 1 bolts (used for the middle and bottom bolts):

$$\text{Proofstrength}_1 := 33000 \text{ psi}$$

Tensile stress area

$$A_{t1} := \frac{\text{Load}_{\text{mid}} \cdot \text{SF}}{\text{Proofstrength}_1}$$

$$A_{t1} = 0.14 \text{ in}^2$$

A standard bolt with a 1/2-in diameter has a tensile stress area of 0.1419-in², approximately the necessary area.

Shear Stress on bolts:

$$\text{ShearLoad} := \frac{\text{Load} + \text{Truss}}{6} \quad \text{ShearLoad} = 96.667 \text{ lbf}$$

$$\tau_{\text{eachbolt}} := \frac{\text{ShearLoad}}{0.1419 \text{ in}^2} \quad \tau_{\text{eachbolt}} = 681.23 \text{ lpsi}$$

Shear stress is not a concern in these bolts.

Appendix C.14 --- Winch Mounting Bolts

Description:

There are two bolts that hold the winch to the roller carts. These bolts came with the carts, and we needed to assure that they were indeed strong enough for holding the load of the tire and the winch.

This sheet helps determine the size and grade needed for these bolts. The method used for these bolt calculations comes from Juvinal & Marshek, Chapter 10.

Assumptions:

-Maximum load of 500-lbf

Results:

We will use the two 1/2-in bolts that came with the carts. They have a very high safety factor in this application.

SAE grade 1 bolts:

Proofstrength := 33000psi

Assume Max load of 500 lb

Load := 500lbf

Safety Factor of 3

FS := 3

Tensile stress area

$$A_t := \frac{\text{Load} \cdot \text{FS}}{2 \cdot \text{Proofstrength}}$$

$$A_t = 0.023\text{in}^2$$

A standard bolt with a 0.2160-in diameter has a tensile stress area of 0.0242-in².

Our bolts are nearly 1/2-in diameter bolts, so they will work.

Appendix C.15 --- Grabber Bending Stress

Description:

The grabber is made out of bend round bar, and must not bend when it is subjected to the load of a tire.

This sheet calculates the bending stress in the grabber "fingers" that wrap under the tire.

Assumptions:

- Max load of 500 lbf
- Treat fingers like a canitlever.

Results:

With 7/8" round bar and 7" long fingers, the stress is 13 ksi, giving a safety factor of 2.7 with respect to the elastic strength limit of 36 ksi.

$D := .875 \text{ in}$ (diameter of bar used)

$I := \frac{\pi \cdot D^4}{64}$ $I = 0.029 \text{ in}^4$

$l := 7 \text{ in}$ (approximate distance from bend that load is concentrated on)

Load := 500 lbf

fingers := 4 (2 grabbers, each with 2 fingers)

$M := \frac{\text{Load}}{\text{fingers}} \cdot l$ $M = 72.917 \text{ lbf} \cdot \text{ft}$

$c := \frac{D}{2}$ $c = 0.438 \text{ in}$

$\sigma := \frac{M \cdot c}{I}$ $\sigma = 13304.054 \text{ psi}$

$S_y := 36000 \text{ psi}$

$SF := \frac{S_y}{\sigma}$ $SF = 2.706$

Appendix C.16 --- Welds back leg pin fin

Description:
 The back legs are pinned to the front legs using a small fin welded to the A-Frame. The welds on this fin must hold the force coming from the back legs.

This sheet calculates the size of the welds needed in this fin using the gusset and truss geometry we have designed. The method used for these weld calculations comes from Juvinall & Marshek, Chapter 11, section 5.

Assumptions:
 -Maximum load of 500 lbf at full 10 ft extension to the front.
 -Desired safety factor of 3.

Results:
 Welds 0.05" thickness will hold with a safety factor of over 3. In reality, the welds on our crane are all much larger than this.

Areas of pieces

Distances from bottom to center of pieces

$$R_1 := .5 \cdot \text{in} \cdot 3 \cdot \text{in}$$

$$D_1 := 1.5 \cdot \text{in}$$

Center of Gravity line

$$\text{CG} := 1.5 \cdot \text{in}$$

Weld distance from CG

Weld Length

$$a_1 := \text{CG}$$

$$L_{h1} := .5 \cdot \text{in}$$

$$L_{v1} := 3 \cdot \text{in}$$

$$a_2 := \text{CG}$$

$$L_{h2} := .5 \cdot \text{in}$$

$$L_{v2} := 3 \cdot \text{in}$$

Vertical I's

$$I_{v1} := \frac{L_{v1}^3 \cdot t}{12}$$

$$I_{v1} \rightarrow \frac{9}{4} \cdot \text{in}^3 \cdot t$$

$$I_{v2} := \frac{L_{v2}^3 \cdot t}{12}$$

$$I_{v2} \rightarrow \frac{9}{4} \cdot \text{in}^3 \cdot t$$

APPENDIX D: PROTOTYPE DESIGN FEA AND MDSOLIDS SIMULATIONS

Appendix D.1 --- Pin Stresses

This appendix shows a Mohr's Circle plot of the maximum stresses in a pin based on the shear and compressive stresses calculated in Appendix C.2. It also shows Algor FEA simulation results of the stresses in a pin.

Mohr's Circle in MDSolids

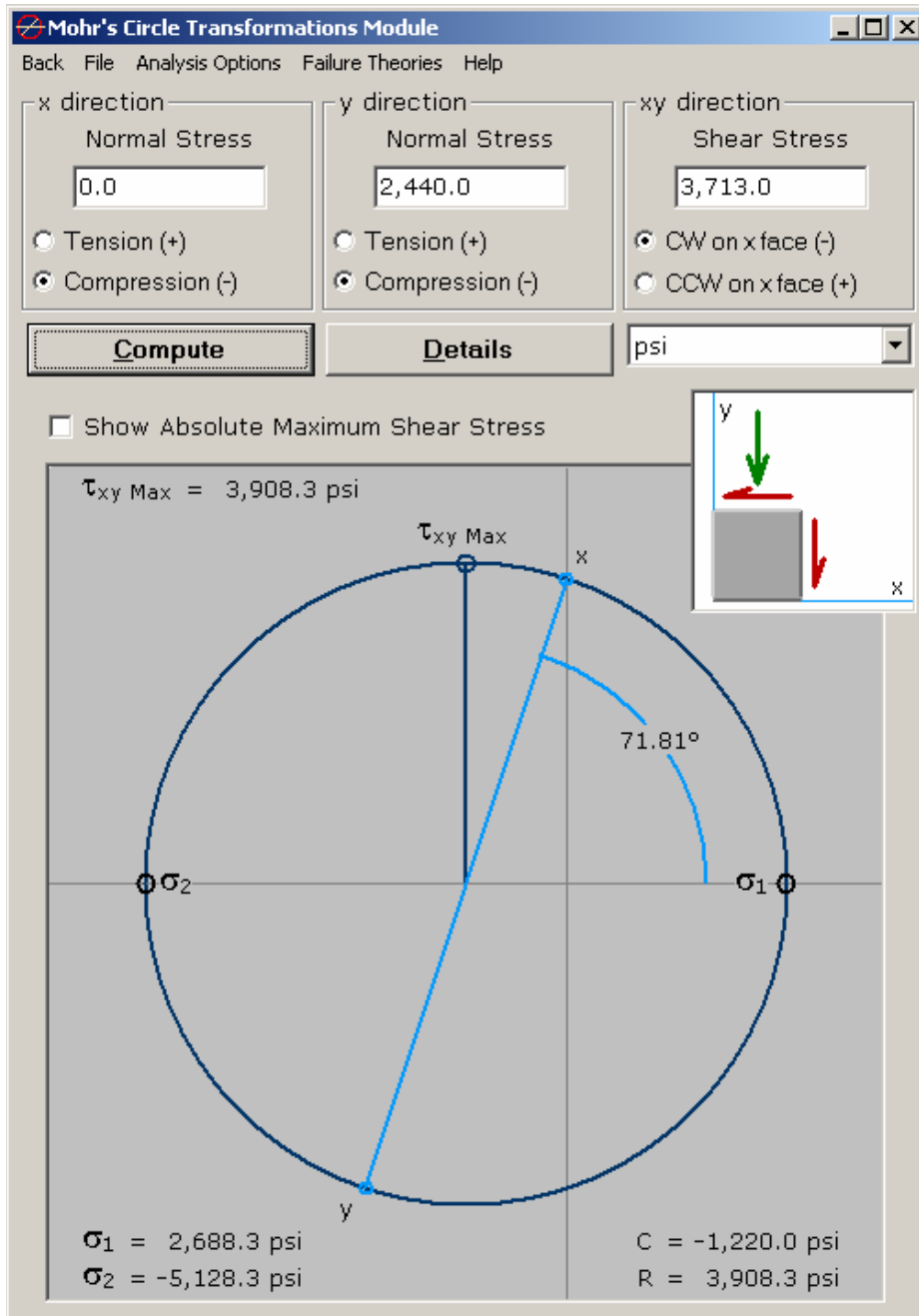

Pin Joint FEA Analysis

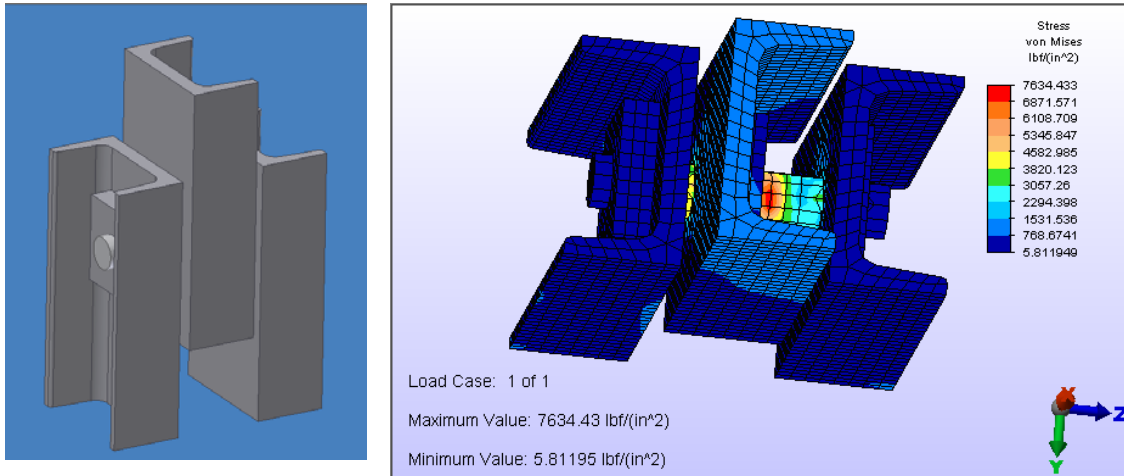

Max stress: 7634 psi

Location of max stress: on middle of pin.

Summary of Test

This FEA analysis was done to estimate the stress in the pins of the pin joints. The pin joint was modeled with 3 pieces of channel and a pin. The two outside pieces of channel had their bottom edges fixed to simulate where they are welded to the base, and the middle channel had a 1600 lbf load placed on its top edge to simulate the reaction force in the crane under a side load.

Practical Meaning of Analysis:

These results are in quite good agreement with the Mathcad pin stress calculations. With these two analyses, we are confident that our pins will not fail.

Appendix D.2 --- FEA and Buckling Analysis of A-frame cross members

An Algor FEA simulation was run on the A-frame with a 700 lbf load on the boom located the right (side load). The A-frame used for this simulation was slightly different than the final prototype design, but it should effectively give the same results as the final prototype design.

The members are named numerically as in the following diagram:

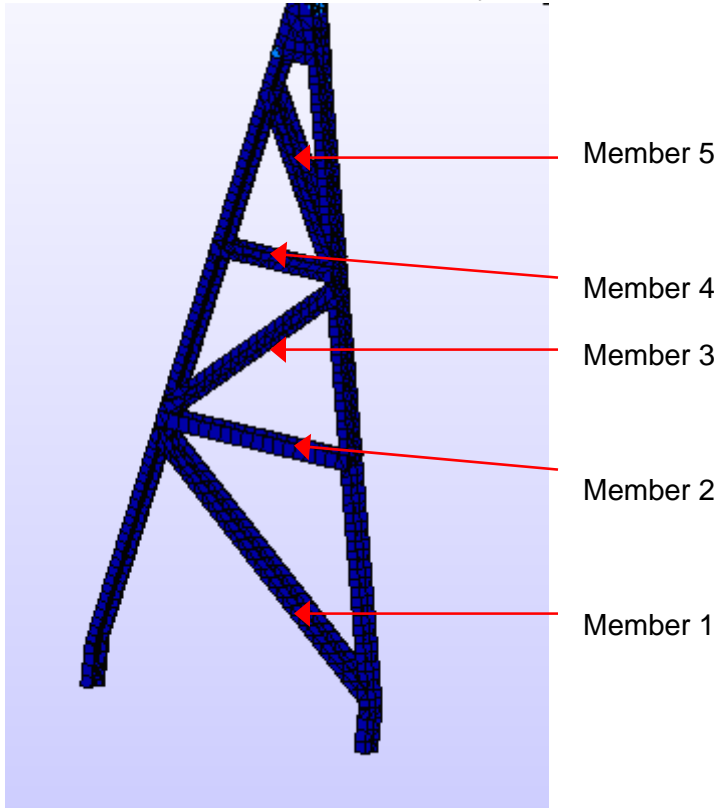

Approximate Stresses (700 lbf load to the right):

- Member 1: 1500 psi
- Member 2: 1200 psi
- Member 3: 3000 psi
- Member 4: 2000 psi
- Member 5: 6500 psi

With load to left, similar results were obtained.

These stresses can then be compared the maximum allowable stress for each piece of flat bar bracing used on the A-frame. This was done in MDSolids. The ends were treated as fixed because they are welded.

Member 1

Length: 45"

Cross section: 2" x 5/16"

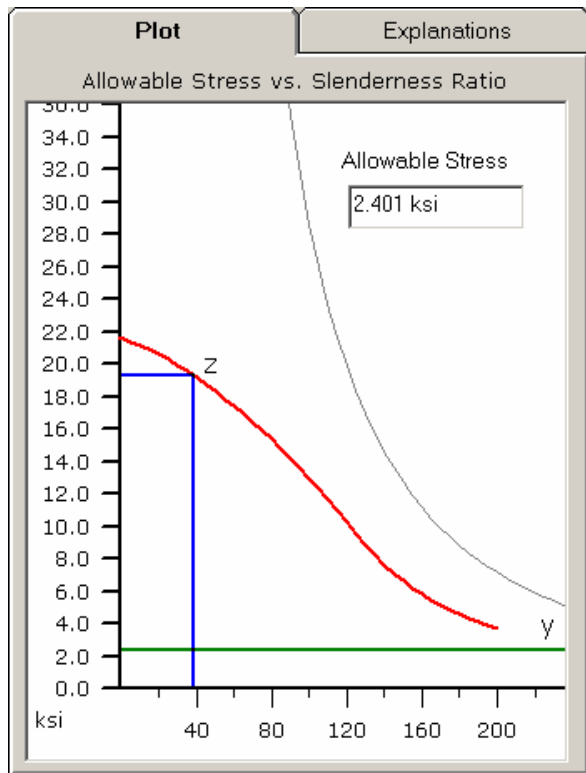

Member 2

Length: 29"

Cross section: 2" x 1/4"

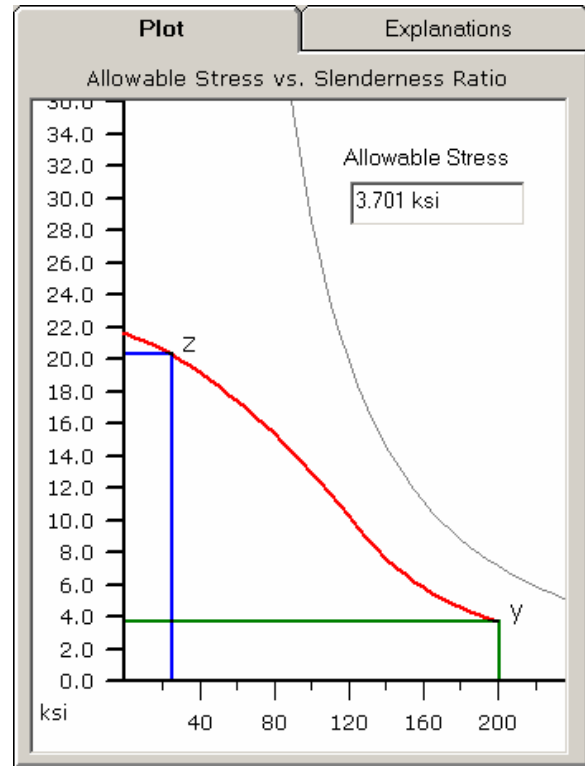

Member 3

Length: 30"

Cross section: 2" x 5/16"

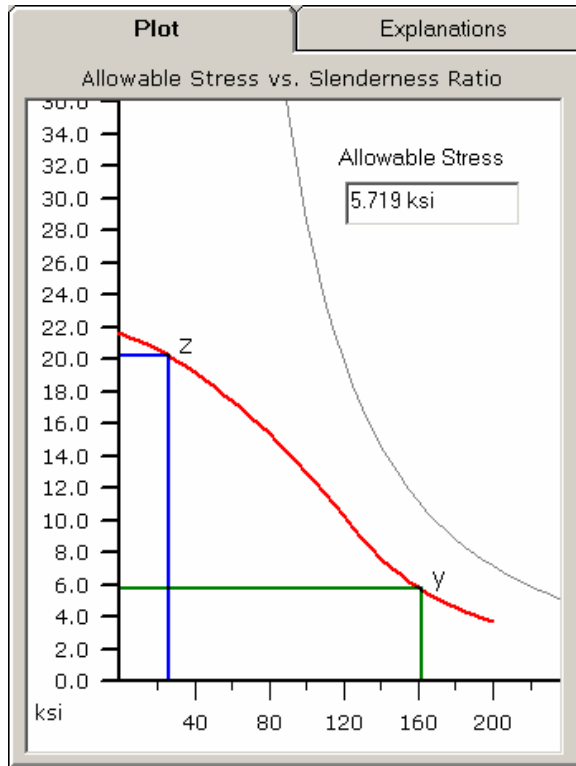

Member 4

Length: 18"

Cross section: 2" x 1/4"

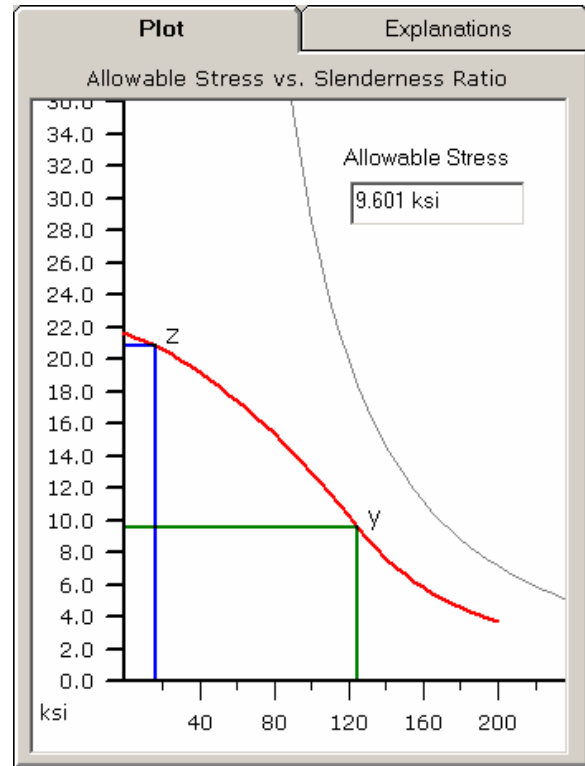

Member 5

Length: 23"

Cross Section: 2" x 5/16"

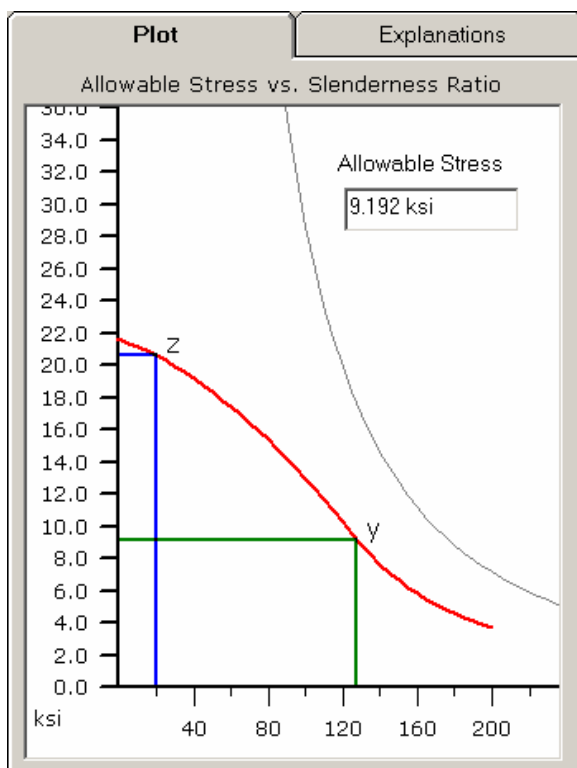

Results

All of the cross-members are below the maximum allowable stress with respect to buckling.

Appendix D.3 --- FEA Analysis of Truss and Buckling of Angle Iron

Algor FEA Simulation of Truss

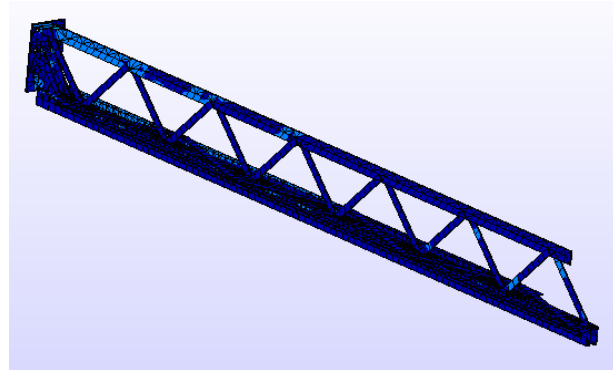
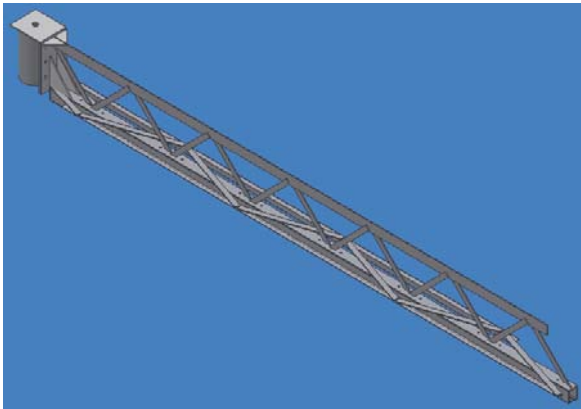

Summary:

Load = 750 lb at a downward angle of 45 degrees

Max stress = 72280 psi

Max displacement = 1.58 in

Location of max stress: At bolt connection and at a gusset connection (awkward mesh)

Location of max displacement: At the free end of the truss

Practical Summary:

The points of high stress were located at the bolt holes where the truss had been fixed. This point has an artificially high stiffness due to being unrealistically fixed. Besides this, the stress will be lowered by washers that were not a part of the Algor model. The other location of high stress was by the gussets at the end of the truss. The model showed a sudden spike of stress around one mesh point that was of an awkward shape. This stress concentration could be attributed to the mesh, and a more accurate stress could be found by testing other point in the area that made up a normal mesh.

The deflection given by the model is believed to be accurate. The deflection of 1.58" is fine given the distance (10 feet) and the material (steel). This deflection is considered normal and safe.

Buckling of Angle Iron

Under a side load, one of the long pieces of angle iron along the side of the truss will be in tension, and the other will be in compression. The one in compression must have short enough lengths between cross supports to not be able to buckle. The longest unbound length on this member is 36-inches. Using MDSolids, it was found that the maximum allowable compressive stress in a member of this 1-inch angle iron of this length is about 20 ksi.

MDSolids Buckling worksheet:

Column Buckling Module
_ _ X

Back File Cross Section Help

Compute

Back

Fixity at Top

Pinned

Fixed

Free

Guided

Slenderness Ratio

$KL/r = 28.754$

Intermediate Support

Effective Length Factor

$K = 0.500$

Fixity at Bottom

Pinned

Fixed

Buckling about the y axis Buckling about the x axis

Column Formulas

Euler Buckling

AISC ASD Formula

Aluminum 2014-T6

Aluminum 6061-T6

AF&PA NDS Wood

Fixity at Top

Pinned

Fixed

Free

Guided

Slenderness Ratio

$KL/r = 28.754$

Intermediate Support

Effective Length Factor

$K = 0.500$

Fixity at Bottom

Pinned

Fixed

Column Length

in

Critical Load

lb

Yield Stress

ksi

Plot

Allowable Stress vs. Slenderness Ratio

Explanations

APPENDIX E: THEORETICAL FUTURE DESIGN MATHCAD CALCULATIONS

Appendix E.1 --- Cable Pre-tensioning system for Truss

Description

After our original prototype design suffered a bending failure of the top pipe, an attempt was made to design a dual cable pre-tensioning system to support the truss and redistribute the load away from the top pipe.

This sheet calculates the bending stress in the top pipe with the specified geometry of the cable system. The sheet is designed to be used to tweak dimensions of the various parts of the system in order to find an optimum design to minimize the stress on the pipe. This sheet shows just a sample of one set of dimensions. We are using the Allowable Stress Design bending limit of 0.66Sy, which for our steel is 24 ksi.

Assumptions:

-Maximum load of 500-lbf at full 10-ft extension

Results:

This system is very complicated and very sensitive to very subtle changes in certain dimensions. After attempting to optimize this design, it was realized that there were much simpler methods of solving the problem of the pipe bending (such as using a larger pipe).

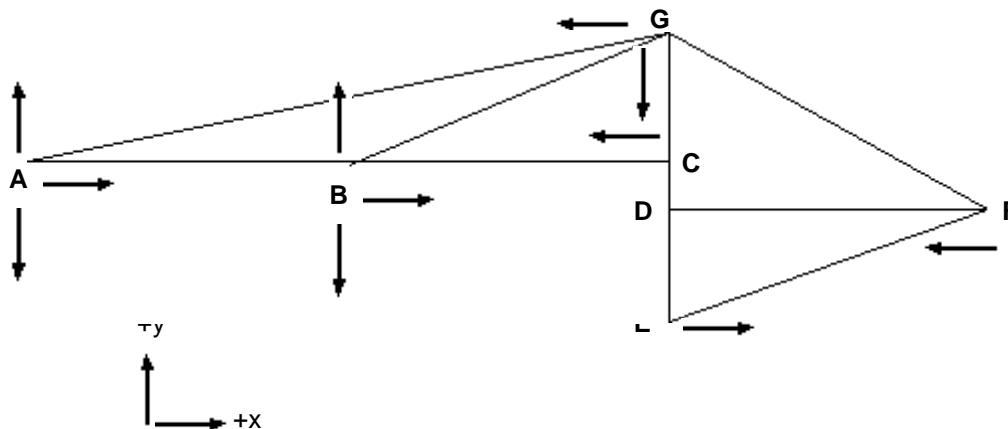

$$L_{AC} := 118\text{in} \quad L_{BC} := 59\text{in} \quad L_{CG} := 24\text{in} \quad L_{CD} := 2\text{in} \quad L_{DE} := 20\text{in} - L_{CD} \quad L_{DF} := 20\text{in}$$

$$L_{GD} := L_{CG} + L_{CD}$$

$$\theta_{GAC} := \text{atan}\left(\frac{L_{CG}}{L_{AC}}\right) \quad \theta_{GBC} := \text{atan}\left(\frac{L_{CG}}{L_{BC}}\right) \quad \theta_{GFD} := \text{atan}\left(\frac{L_{GD}}{L_{DF}}\right) \quad \theta_{DFE} := \text{atan}\left(\frac{L_{DE}}{L_{DF}}\right)$$

$$\theta_{CGF} := 90\text{deg} - \theta_{GFD} \quad \theta_{BGC} := 90\text{deg} - \theta_{GBC} \quad \theta_{AGC} := 90\text{deg} - \theta_{GAC}$$

Pretension

$$T := 1045 \text{ lbf}$$

$$FA_x := T \cdot \cos(\theta_{GAC}) \quad FA_x = 1024 \text{ lbf}$$

$$FA_y := T \cdot \sin(\theta_{GAC}) \quad FA_y = 208.3 \text{ lbf}$$

$$FB_x := T \cdot \cos(\theta_{GBC}) \quad FB_x = 968 \text{ lbf}$$

$$FB_y := T \cdot \sin(\theta_{GBC}) \quad FB_y = 393.8 \text{ lbf}$$

$$FE_x := 2T \cdot \cos(\theta_{DFE}) \quad FE_x = 1553.5 \text{ lbf}$$

$$FE_y := 2T \cdot \sin(\theta_{DFE}) \quad FE_y = 1398.1 \text{ lbf}$$

$$FF_x := -2T \cdot \cos(\theta_{GFD}) - FE_x \quad FF_x = -2827.8 \text{ lbf}$$

$$FF_y := 2T \cdot \sin(\theta_{GFD}) - FE_y \quad FF_y = 258.4 \text{ lbf}$$

$$FG_x := FF_x + FA_x + FB_x \quad FG_x = -835.8 \text{ lbf}$$

$$FG_y := -FA_y - FB_y - FF_y \quad FG_y = -860.5 \text{ lbf}$$

Moment from truss weight:

$$\text{Truss} := 94 \text{ lbf}$$

$$M_{\text{truss}} := \text{Truss} \cdot 5 \text{ ft} \quad M_{\text{truss}} = 470 \text{ lbf} \cdot \text{ft}$$

Moment from back truss:

$$\text{Backweight} := 7 \cdot \frac{\text{lbf}}{\text{ft}} \quad (\text{estimated})$$

$$M_{\text{back}} := \text{Backweight} \cdot (L_{DF} - 3 \text{ in}) \cdot \frac{L_{DF}}{2}$$

$$M_{\text{back}} = 8.3 \text{ lbf} \cdot \text{ft}$$

Forces on top of pipe (transmitted through thrust bearing)

Boxed quantities are forces on the top of the pipe

$$FA_{px} := FA_x \cdot \left(\frac{10 \text{ in}}{8 \text{ in}} \right) \quad \boxed{FA_{px} = 1280 \text{ lbf}}$$

$$FA_{py} := \frac{FA_y \cdot L_{AC}}{8 \text{ in}} \quad \boxed{FA_{py} = 3072.1 \text{ lbf}}$$

$$FB_{px} := FB_x \cdot \left(\frac{10 \text{ in}}{8 \text{ in}} \right) \quad \boxed{FB_{px} = 1210 \text{ lbf}}$$

$$FB_{py} := \frac{FB_y \cdot L_{BC}}{8 \text{ in}} \quad \boxed{FB_{py} = 2903.9 \text{ lbf}}$$

$$FF_{px} := R_{\text{thrust}} + \frac{R_{\text{rad}} \cdot 5 \text{ in}}{8 \text{ in}} \quad \boxed{FF_{px} = -2827.8 \text{ lbf}}$$

$$FF_{py} := \frac{-FF_y \cdot L_{DF}}{8 \text{ in}} \quad \boxed{FF_{py} = -646.1 \text{ lbf}}$$

$$FG_{px} := FG_x \cdot \left(\frac{34 \text{ in}}{8 \text{ in}} \right) \quad \boxed{FG_{px} = -3552 \text{ lbf}}$$

$$F_{\text{pipe } x} := FA_{px} + FA_{py} + FB_{px} + FB_{py} + FG_{px} + FF_{py} + FF_{px} + F_{\text{truss } p} + F_{\text{back } p}$$

Forces from weight of truss:

$$F_{\text{truss } p} := \frac{-M_{\text{truss}}}{8 \text{ in}} \quad \boxed{F_{\text{truss } p} = -705 \text{ lbf}}$$

$$F_{\text{back } p} := \frac{M_{\text{back}}}{8 \text{ in}} \quad \boxed{F_{\text{back } p} = 12.4 \text{ lbf}}$$

Forces from FFx:

$$R_{\text{rad}} := \frac{FF_x \cdot (L_{CD} - 2 \text{ in})}{7.5 \text{ in}}$$

$$R_{\text{thrust}} := FF_x - R_{\text{rad}}$$

$$R_{\text{rad}} = 0 \text{ lbf}$$

$$R_{\text{thrust}} = -2827.8 \text{ lbf}$$

This is the positive direction bending force on top of pipe due to pretensioned cables

$$F_{\text{pipe}_x} = 747.5 \text{ lbf}$$

Shear on pipe

$$F_{\text{shear}} := 3877 \text{ lbf}$$

$$A_{\text{pipe}} := 1.075 \text{ in}^2$$

$$\tau := \frac{F_{\text{shear}}}{A_{\text{pipe}}} \quad \tau = 3606.5 \text{ psi}$$

PIPE

$$E := 29 \cdot 10^6 \text{ psi}$$

$$D := 2.375 \text{ in} \quad d := 2.067 \text{ in}$$

$$I := .666 \text{ in}^4$$

$$L := 8 \text{ in}$$

Bending Load:

Force := 1600 lbf
 This is max bending force pipe can have at the top of it

$$\text{strength}_{\text{tensile}} := 36000 \text{ psi}$$

$$M := \text{Force} \cdot L \quad M = 1066.7 \text{ lbf} \cdot \text{ft}$$

$$\sigma_{\text{bend}} := \frac{M \cdot \frac{D}{2}}{I} \quad \sigma_{\text{bend}} = 22822.8 \text{ psi}$$

Need under 23760 psi

Moment caused by load:

$$M_{\text{load}} := 5000 \text{ ft} \cdot \text{lbf}$$

Moment from cables pulling up on truss and load pulling down::

$$M_{\text{loaded}} := F_{A_y} \cdot L_{AC} + F_{B_y} \cdot L_{BC} - M_{\text{load}}$$

$$M_{\text{loaded}} = -1016 \text{ ft} \cdot \text{lbf}$$

$$F_{\text{pipeloaded}} := \frac{M_{\text{loaded}}}{8 \text{ in}} + F_{\text{pipe}_x}$$

$$F_{\text{pipeloaded}} = -776.4 \text{ lbf}$$

Needs to be less than 1600 to barely pass!

Appendix E.2 --- Reaction Forces and A-frame bending stress, front extension (Theoretical)

Description:

The reaction forces at the front and back legs are necessary for calculating stresses in the pins at each joint, and also for calculating bending, compressive, and tensile stresses in the legs of the crane.

This sheet calculates estimates of the reaction forces at each foot of the crane for a front loading condition using simple static analysis techniques. It then calculates the level of **bending stress in the front legs** when different sizes of channel are used for the A-frame.

Assumptions:

-Maximum load of 500-lbf at full 10-ft extension off the front.

Results:

Using C4x5.4 channel, the safety factor for bending is between 1.4 and 2.4 with respect to ASD standards. This is still not satisfactory.

Using C5x6.7 channel adds about 15-20 lbf to the A-frame, but gives a safety factor between 2.2 and 3.6.

Dimensions and Loads

$h := 104 \text{ in}$ (length AD) $d := 89 \text{ in}$ (length CD)

$h_t := 120 \text{ in}$ (total height, length ED)

$l_{\text{arm}} := 10 \text{ ft}$ Load := 500 lbf

$\theta := \text{atan}\left(\frac{d}{h}\right)$ $\theta = 40.556 \text{ deg}$

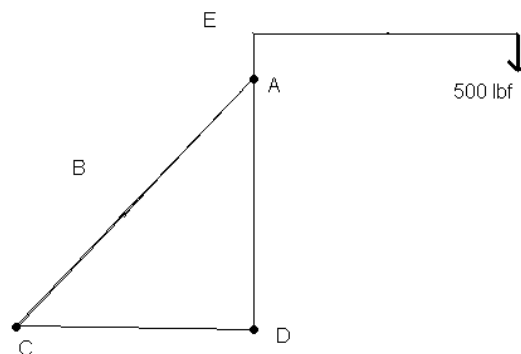

$M := \text{Load} \cdot l_{\text{arm}} + \text{truss} \cdot \frac{l_{\text{arm}}}{2}$ $M = 5400 \text{ lbf} \cdot \text{ft}$

$$F_A := \frac{M}{h \cdot \sin(\theta) \cdot 2} \quad (\text{Moments about } D) \quad F_A = 479.15 \text{ lbf} \quad (T)$$

$$F_{Dx} := \frac{M}{h \cdot 2} \quad (\text{Moments about } A) \quad F_{Dx} = 311.538 \text{ lbf}$$

$$F_{Dy} := \frac{\text{Load} + \text{truss} + 2 \cdot F_A \cdot \cos(\theta)}{2} \quad (\text{Sum of y-forces}) \quad F_{Dy} = 654.045 \text{ lbf} \quad (C)$$

$$F_D := \sqrt{F_{Dx}^2 + F_{Dy}^2} \quad (\text{Gives magnitude of force on pins}) \quad F_D = 724.452 \text{ lbf}$$

Bending Stress in A-Frame legs (worst case without the cross bracing):

For a theoretical design, we propose using C4x5.4 channel. This saves weight and gives better bending rigidity in both directions.

$$I_{\text{channel}} := 3.85 \text{ in}^4$$

$$M := \text{Load} \cdot l_{\text{arm}} + \text{truss} \cdot \frac{l_{\text{arm}}}{2}$$

(Since the bottoms of the front legs are just pinned, the force from the back legs does nothing to counteract the bending moment)

$$M = 5400 \text{ ft} \cdot \text{lbf}$$

$$c := 2 \cdot \text{in} \quad (\text{half the width of the channel})$$

$$\sigma_{\text{bendfront}} := \frac{M \cdot c}{I_{\text{channel}} \cdot 2} \quad (\text{Moment of Inertia of channel is multiplied by 2 because there are 2 legs})$$

$$\sigma_{\text{bendfront}} = 16831.169 \text{ psi}$$

$$\text{target} := 36000 \text{ psi} \cdot \frac{2}{3} \quad (\text{Allowable Stress Design bending standard})$$

$$\text{SF} := \frac{\text{target}}{\sigma_{\text{bendfront}}} \quad \boxed{\text{SF} = 1.426} \quad \text{This is not good.}$$

Bending Stress in A-Frame legs (best case with cross bracing adding to the moment of Inertia):

$$I_{\text{flatbar}} := \frac{[1.584 \text{ in} \cdot (4.5 \text{ in})^3] - [1.584 \text{ in} \cdot (4 \text{ in})^3]}{12} \quad I_{\text{flatbar}} = 3.581 \text{ in}^4$$

$$I_{\text{bestcase}} := I_{\text{channel}} + I_{\text{flatbar}} \quad I_{\text{bestcase}} = 7.431 \text{ in}^4$$

$$c_{\text{bestcase}} := 2.25 \text{ in}$$

$$\sigma_{\text{bendbest}} := \frac{M \cdot c_{\text{bestcase}}}{I_{\text{bestcase}} \cdot 2} \quad \sigma_{\text{bendbest}} = 9810.914 \text{psi}$$

$$SF_{\text{best}} := \frac{\text{target}}{\sigma_{\text{bendbest}}} \quad \boxed{SF_{\text{best}} = 2.446}$$

To use 4-inch channel for the A-frame, the pipe at the top that slips over the A-frame would need to be a Standard Size 5 pipe, and the corners of the channel would have to be ground down slightly.

What if we upgraded to C5x6.7 channel? This would add about 15-20 lbs to our A-frame.

$$I_{\text{channel5}} := 7.49 \text{in}^4$$

$$c_5 := 2.5 \text{in} \quad (\text{half the width of the channel})$$

$$\sigma_{\text{bendfront5}} := \frac{M \cdot c_5}{I_{\text{channel5}} \cdot 2} \quad (\text{Moment of Inertia of channel is multiplied by 2 because there are 2 legs})$$

$$\sigma_{\text{bendfront5}} = 10814.419 \text{psi}$$

$$SF := \frac{\text{target}}{\sigma_{\text{bendfront5}}} \quad \boxed{SF = 2.219} \quad (\text{worst case, no bracing})$$

Bending Stress in A-Frame legs (best case with cross bracing adding to the moment of Inertia):

$$I_{\text{flatbar5}} := \frac{\left[1.750 \text{in} \cdot (5.5 \text{in})^3 \right] - \left[1.750 \text{in} \cdot (5 \text{in})^3 \right]}{12} \quad I_{\text{flatbar5}} = 6.034 \text{in}^4$$

$$I_{\text{bestcase5}} := I_{\text{channel5}} + I_{\text{flatbar5}} \quad I_{\text{bestcase5}} = 13.524 \text{in}^4$$

$$c_{\text{bestcase5}} := 2.75 \text{in}$$

$$\sigma_{\text{bendbest5}} := \frac{M \cdot c_{\text{bestcase5}}}{I_{\text{bestcase5}} \cdot 2} \quad \sigma_{\text{bendbest5}} = 6588.359 \text{psi}$$

$$SF_{\text{best5}} := \frac{\text{target}}{\sigma_{\text{bendbest5}}} \quad \boxed{SF_{\text{best5}} = 3.643}$$

To use 5 inch channel for the A-frame, the pipe at the top that slips over the A-frame would need to be a Standard Size 6 pipe, and the corners of the channel would have to be ground down slightly.

Appendix E.3 --- Top channel and pipe bending (Theoretical)

Description:

In our prototype design, the safety factor in the bending of the top swivel connection on the A-Frame is not at a desirable level. A design change that could fix this is using a larger diameter pipe for the truss to swivel around, and mounting it to the channel using a few spacers. The pipe should also be longer in length so that it can extend all the way down to where the A-frame legs begin to bend out, thus eliminating the weak spot in that location of our prototype design.

This sheet calculates the bending stress in these three parts assuming that they are all fixed together. We are using the Allowable Stress Design bending limit of $0.66S_y$, which for our steel is 24 ksi.

Assumptions:

- Maximum load of 500-lbf at full 10-ft extension
- Orientation is such that the moment of inertia for the channel is minimized to model worst case scenario

Results:

With the larger diameter pipe (Standard Size 6 instead of Size 4) combined with the 5-inch channel of the A-frame, the safety factor increases to almost 4.

Moments of inertia for each component of this assembly:

OUTER PIPE: The new pipe would be a Standard Weight 6 pipe

$$D := 6.625 \text{ in} \quad d := 6.065 \text{ in}$$

$$I_{\text{outer}} := \frac{\pi \cdot \left[\left(\frac{D}{2} \right)^4 - \left(\frac{d}{2} \right)^4 \right]}{4} \quad I_{\text{outer}} = 28.142 \text{ in}^4$$

CHANNEL: The new channel would be C5x6.7 standard channel

$$b_o := 5 \text{ in} \quad b_i := 4.36 \text{ in}$$

$$h_o := 3.5 \text{ in} \quad h_i := 3.12 \text{ in}$$

This is the moment of inertia of the two pieces of channel across their weak axis.

$$I_{\text{channelweak}} := \frac{b_o \cdot h_o^3}{12} - \frac{b_i \cdot h_i^3}{12} \quad I_{\text{channelweak}} = 6.83 \text{ in}^4$$

INNER PIPE:

$$D_1 := 2.375 \text{ in} \quad d_1 := 2.067 \text{ in}$$

$$I_{\text{inner}} := \frac{\pi \cdot \left[\left(\frac{D_1}{2} \right)^4 - \left(\frac{d_1}{2} \right)^4 \right]}{4} \quad I_{\text{inner}} = 0.666 \text{ in}^4$$

TOTAL moment of inertia:

$$I := I_{\text{outer}} + I_{\text{channelweak}} + I_{\text{inner}} \quad \boxed{I = 35.638 \text{ in}^4}$$

Moment and force:

$$\text{Load} := 500 \text{ lbf} \quad \text{Truss} := 80 \text{ lbf}$$

$$\text{Arm} := 10 \text{ ft}$$

$$M := \text{Load} \cdot \text{Arm} + \text{Truss} \cdot \frac{\text{Arm}}{2} \quad M = 5400 \text{ ft} \cdot \text{lbf}$$

Strength of steel:

$$\text{strength}_{\text{tensile}} := 36000 \text{ psi}$$

$$\text{target} := \frac{2}{3} \cdot \text{strength}_{\text{tensile}}$$

Bending Stress of all three components:

$$\sigma_{\text{bend}} := \frac{M \cdot \frac{D}{2}}{I} \quad \sigma_{\text{bend}} = 6023.134 \text{ psi}$$

$$\text{SF} := \frac{\text{target}}{\sigma_{\text{bend}}} \quad \boxed{\text{SF} = 3.985}$$